

# RAPIDO

**FORMWORK  
SCAFFOLDING  
SYSTEMS  
2020**

**SINCE'96**

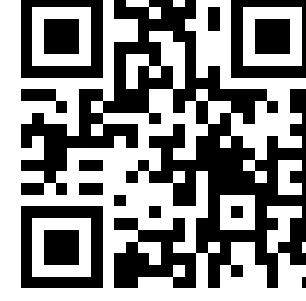

Web



Youtube



References

## FABRİKA - DİLOVASI

**Fabrika** : Dilovası Mermerciler Sanayi Sitesi 3. Cd. No:40 Köşeler Köyü  
Dilovası / KOCAELİ / TÜRKİYE

**Telefon** : +90 262 742 06 37  
**Faks** : +90 262 742 08 37  
**Web** : ozleriskele.com  
**e-mail** : info@ozleriskele.com - fabrika@ozleriskele.com

## EGE BÖLGE MÜDÜRLÜĞÜ

**Bölge Müdürlüğü** : Kavaklıdere Mah. Ankara Cd. No:405/1  
Bornova / İZMİR

**Telefon / Phone** : +90 232 479 01 37  
**Bölge Müdürü** : Erdi AYHAN  
**e-mail** : erdi.ayhan@ozleriskele.com

## RAPIDO / PANEL KALIP SİSTEMİ

RAPIDO vinç ile taşınan, çelik çerçeveli, plywood yüzeyli panel kalıp sistemidir. Sistemin ana çerçevesinde Welsler profil tarafından dizayn edilmiş, burulmaya karşı mukavemet değeri yüksek özel şekillendirilmiş S355 MC çelik profil kullanılmaktadır. Panel yüzeylerinde 21 mm birch plywood kullanılmaktadır. Panel genişlikleri, 30-45-60-75-90-105-120-240 cm ve yükseklikleri ise, 60-90-120-150-180-210-240-270-300-330 cm olarak üretilmektedir. RAPIDO-UNI panellerde kullanılan 5 cm'de bir delinmiş perfore profiller sayesinde her ebat perde ve kolon kalıbı kolayca ayarlanıp dökülebilir. RAPIDO kalıp sistemi 80 kN/m<sup>2</sup> taze beton basıncına göre dizayn edilmiştir. Üretimlerimizde robotik kesme, delme ve kaynak prosesleri uygulanmaktadır. Paneller, fırın boya işlemine tabi tutulmadan önce kumlama yapılarak yüzeyindeki kimyasal yağlardan arındırılır. Ayrıca talep halinde ürünlerimiz TS 914 EN ISO 1461 standartlarına göre daldırma galvaniz kaplanabilir.

## RAPIDO / PANEL FORMWORK SYSTEM

RAPIDO is a panel formwork system that is carried by crane and consists of steel frames with plywood on the surface. The profile used in the system's main frame is a special shaped steel profile S355 MC with high resistance against bending designed by Welsler Profile. 21 mm birch plywood is used on the surfaces of the panels. The panels are valid in the following widths: 30-45-60-75-90-105-120-240cm and the following heights: 60-90-120-150-180-210-240-270-300-330cm. Owing to the perforated profile that has a hole every 5 cm, columns and shear walls with any desired dimensions can be casted by adjusting the formwork. Rapido formwork system is designed according to 80 kN/m<sup>2</sup> fresh concrete pressure. In our production procedure robotic cutting, drilling and welding processes are used. However, before the oven painting procedure panels are sandblasted in order to be purified and cleaned from the oils and chemicals on its surface. In case of request products can also be hot dip galvanized according to TS 914 EN ISO 1461 standards.

**RAPIDO****PANEL KALIP SİSTEMİ  
PANEL FORMWORK SYSTEM**

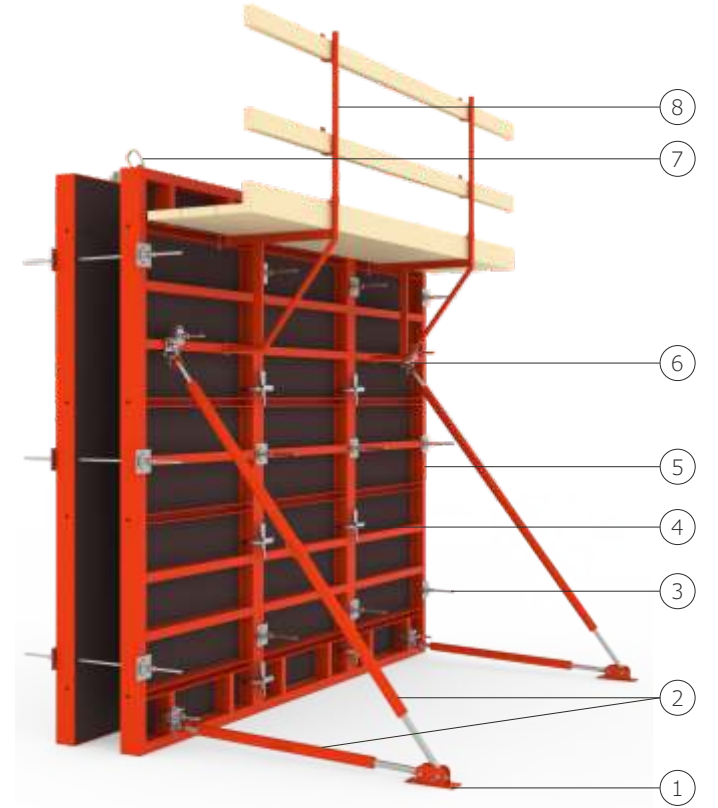
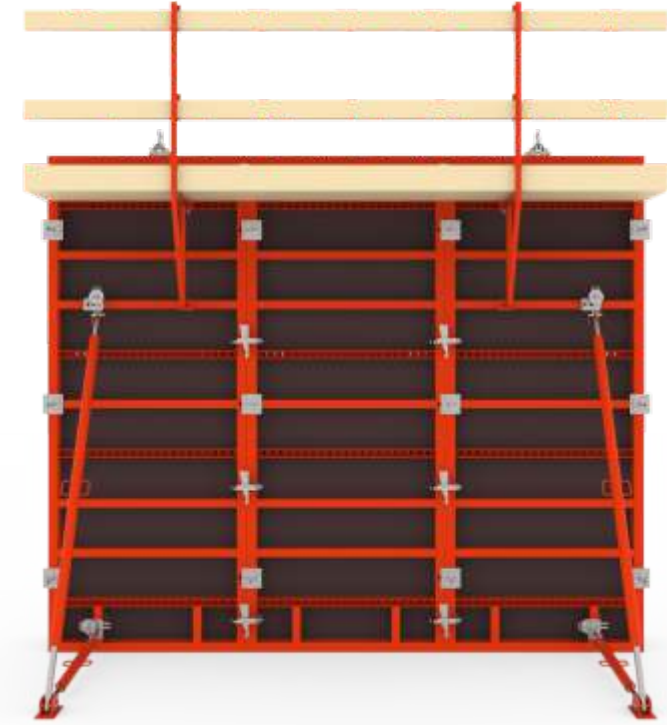
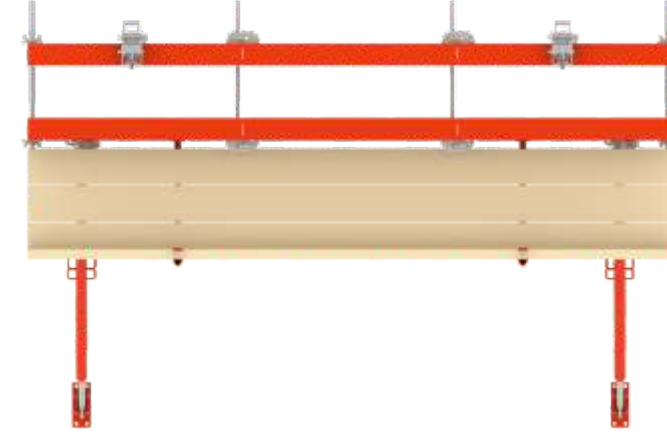

Rapido perde kalıbı tipik planı, görünüşü ve kesiti / Rapido wall formwork typical plan, view and section.

- 1 - Payanda Tabanı Çiftli / Base Plate Double
- 2 - Payanda / Push Pull Prop
- 3 - Tie-Rod + Somun + Ayna / Tie-Rod + Nut + Plate
- 4 - Rapido Kilit - Standart / Rapido Lock - Standard
- 5 - Rapido-Uni Panel / Rapido-Uni Panel
- 6 - Rapido Payanda Kafası + Somun / Rapido Push Pull Prop Head + Nut
- 7 - Rapido Vinç Kulbu / Rapido Crane Hook
- 8 - Rapido Çalışma Konsolu / Rapido Bracket

Rapido-Uni paneller hem yatay hem de dikey olarak kullanılabilirlerdir.  
Rapido panels can be used both horizontally and vertically.

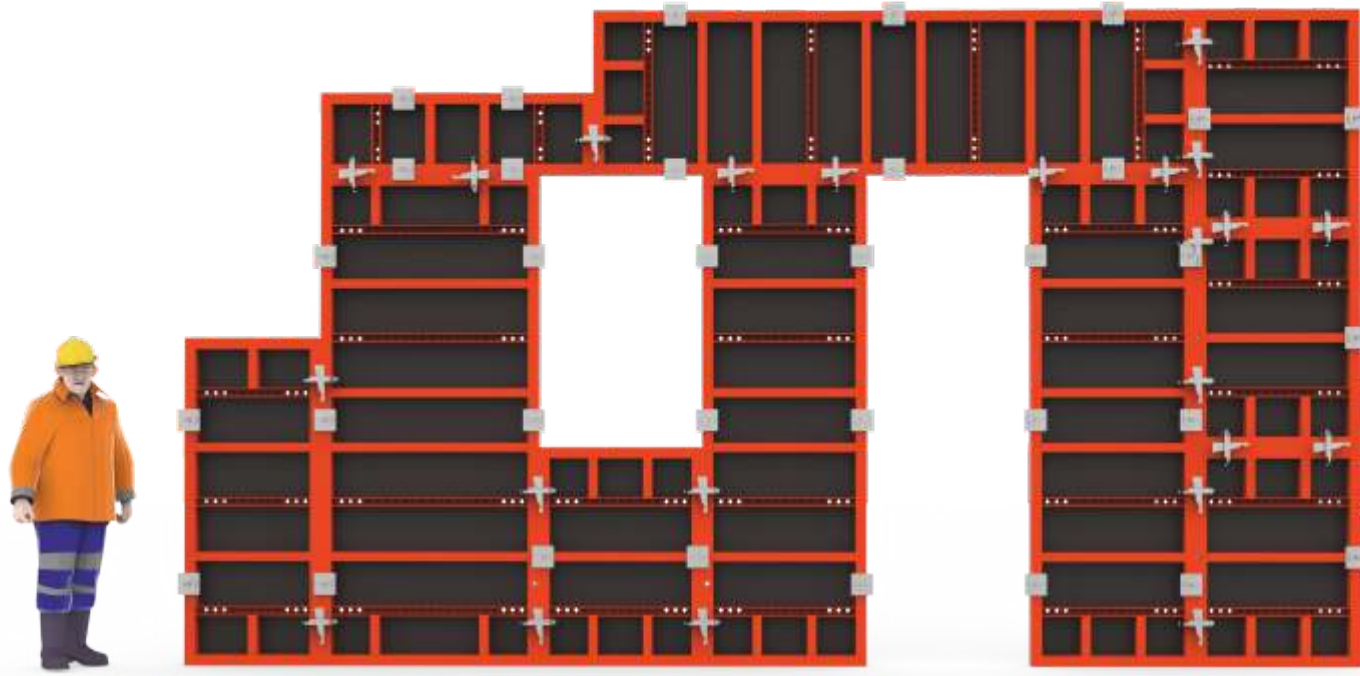

## Rapido-Uni Panellere Genel Bakış

Rapido-Uni Panels Overview

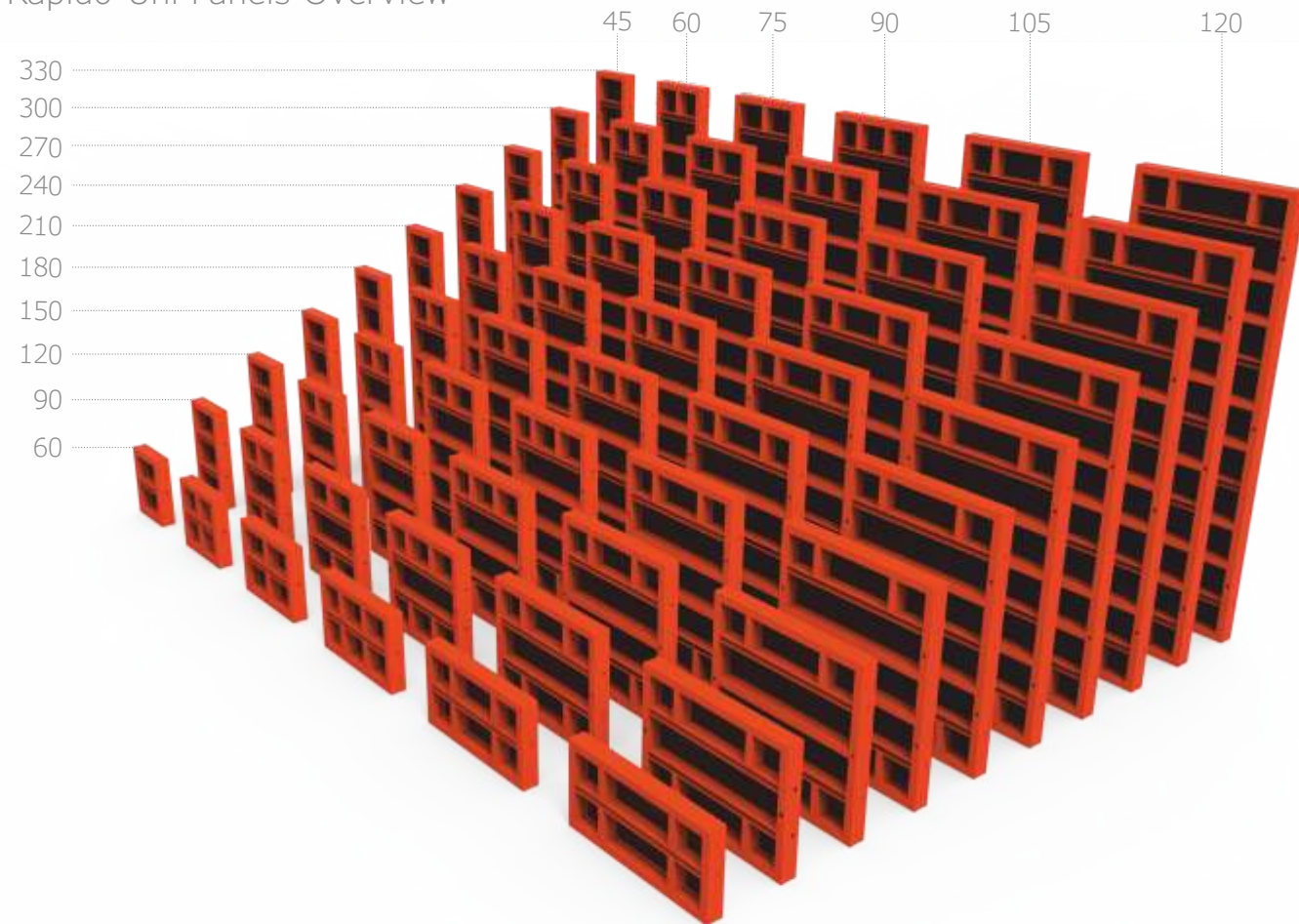

# RAPIDOX

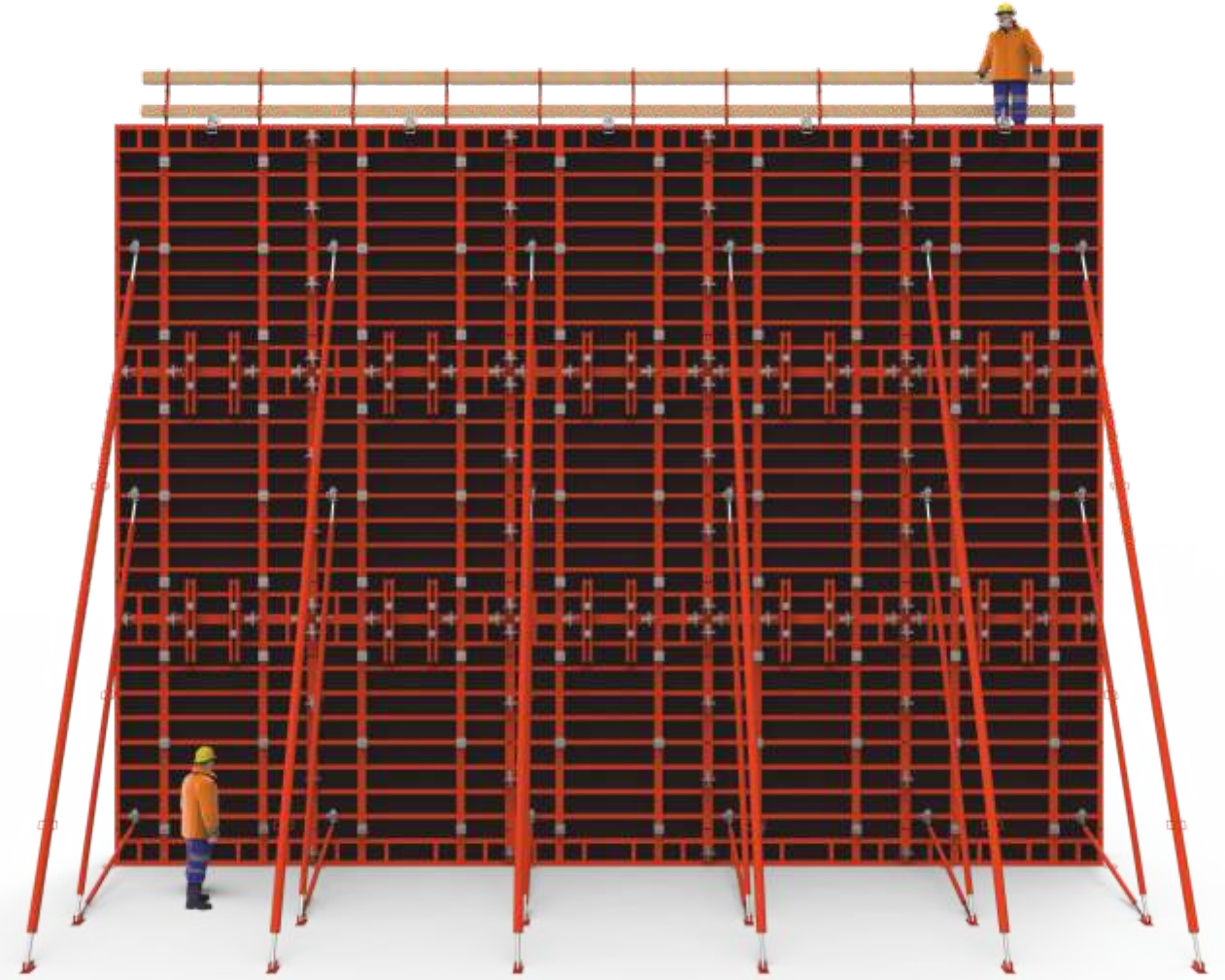

KOD CODE	BOYUT cm SIZE cm	AĞIRLIK kg WEIGHT kg
202308005	240 x 270	353,5
202309005	240 * 300	389,0
202310005	240 * 330	424,5

**FAST  
TIME  
COST**



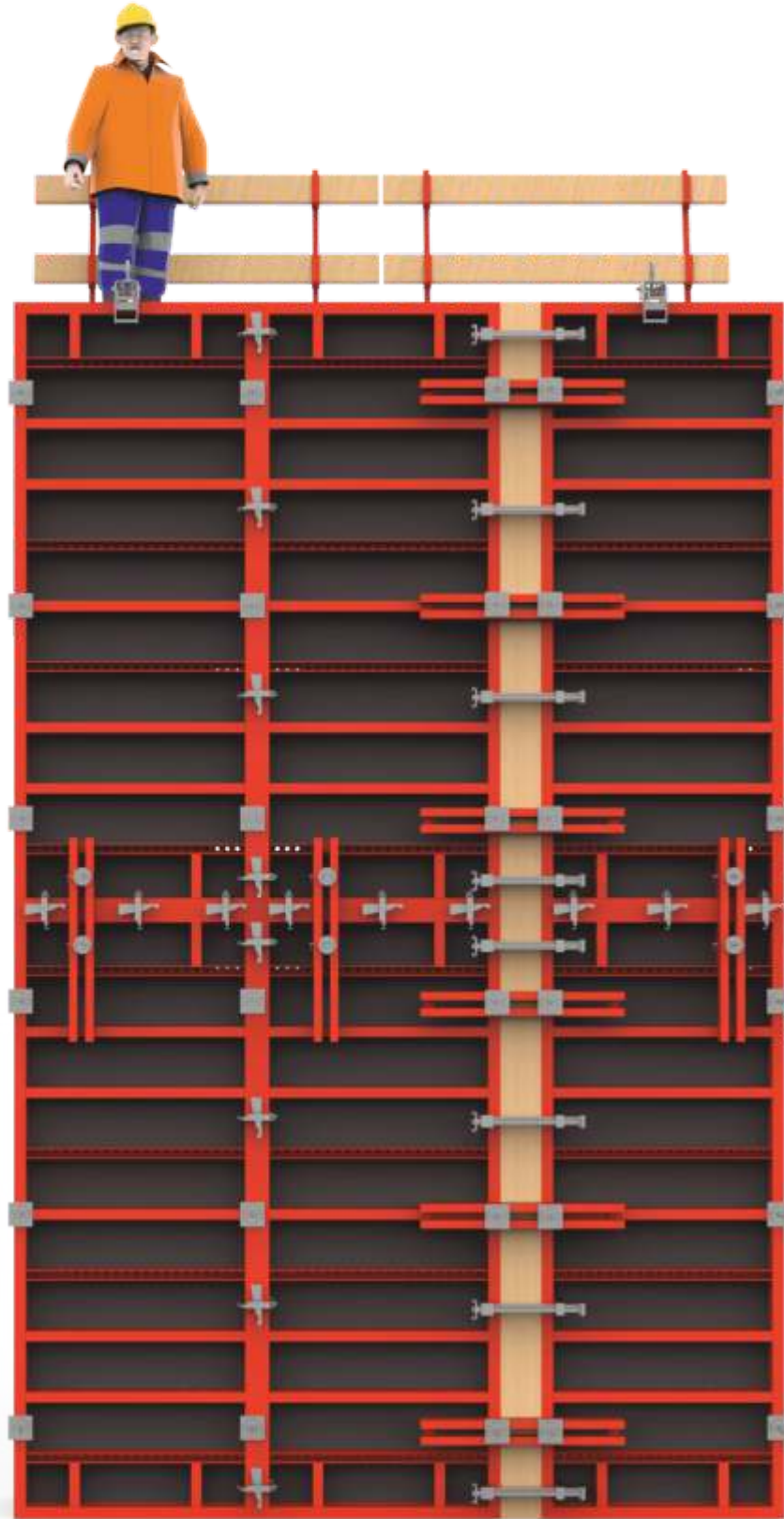

**Rapido perde kalıbı tipik görünüşü**  
Rapido wall formwork typical view

## Rapido Kilit - Standart

Rapido Lock - Standard



Rapido standart kilitler profil geometrisine uygun olarak üretilmektedir. Paneller arasında güçlü bir bağlantı sağlar. Panellerin hizalanmasına yardımcı olur.

Rapido standard lock is produced according to the shape of the profile. It provides stability, connects and holds panels together. It also helps in the alignment of panels.

## Rapido Kilit - Ayarlanabilir

Rapido Lock - Adjustable

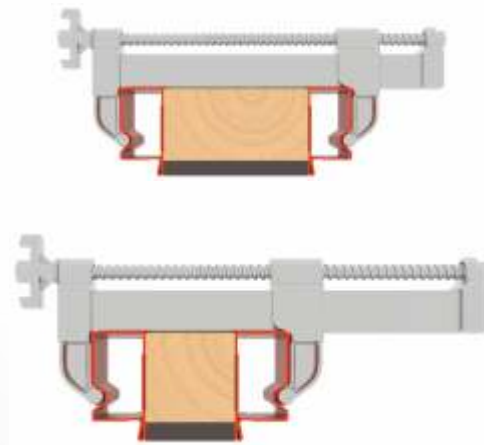

Rapido ayarlanabilir kilit ile paneller arasında 20 cm'ye kadar dolgu yapmak mümkündür.

The maximum applicable width of a filling fastened by Rapido Adjustable Lock is 20 cm.

## Rapido Çalışma Konsolu / Rapido Bracket

Rapido çalışma konsolu, panel üzerine montajlanarak işçilere güvenli çalışma ortamı sağlamak amacıyla kullanılır. Yürüme platformu oluşturulmasına imkan sağlar. Panellerle beraber taşınabilir. Kalıp yüksekliğinin fazla olduğu durumlarda farklı kotlarda çalışma platformu oluşturmak gerekebilir.

Rapido bracket is mounted on the panels to provide a safe working area for the workers. It also serve as a platform for walking. It can be carried together with the panels. In some cases where the formwork is very big in height, working brackets are used at several different elevations.

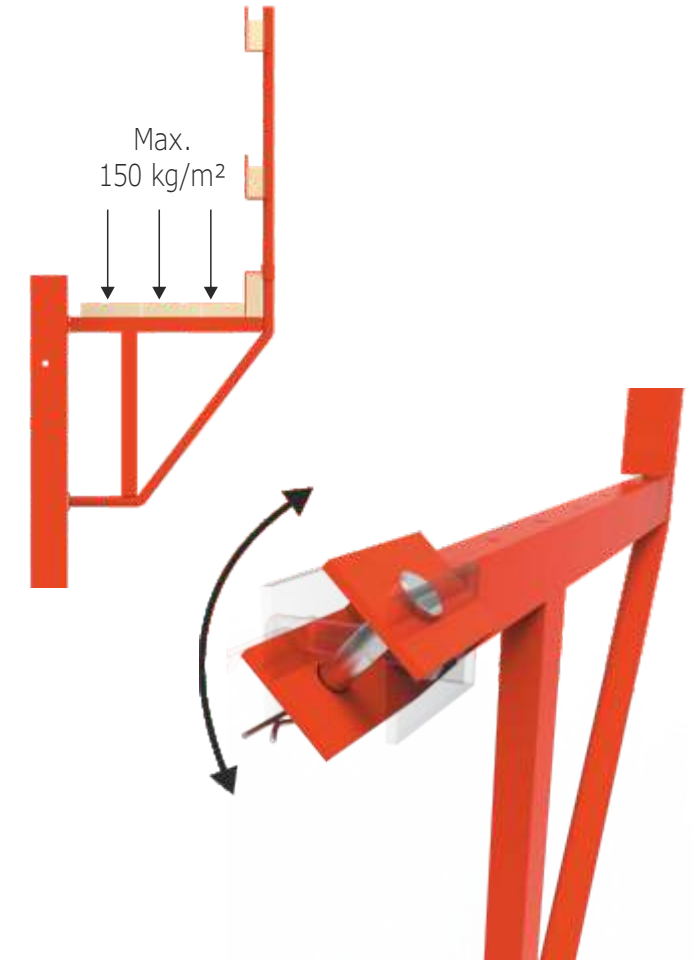

## Payanda / Push Pull Prop

Payandalar kalıpları şaküle getirmek amacıyla kullanılan ayrıca kurulum sırasında kalıpların devrilmesini engelleyen destek sistemidir. Payandaların zemine yaptığı açının 60° yi geçmeyecek şekilde olması gerekir.

Push and pull props are used for the vertical alignment of the panels. They also prevent panels from tilting over during the assembly process. The angle between the upper push pull props and the ground must not be bigger than 60 degrees.



## Rapido Destek Kuşağı / Rapido Support Waler

Rapido destek kuşakları panellerin üst üste montajlanması halinde panelleri, ahşap dolgu kullanılması durumunda da dolguyu desteklemek amacıyla kullanılır.

Rapido support walers are used as panels are mounted each other and behind the filling.



## Rapido Vinç Kulbu / Rapido Crane Hook

Paneller vinç kulbu yardımıyla taşınır. Taşınacak kalıba en az iki adet vinç kulbu bağlanmalıdır. Vinç kulplarının kalıba güvenli bir şekilde bağlandığı ve emniyet pimlerinin takılmış olduğu kontrol edilmelidir. Kalıp üzerine bağlı 2 adet vinç kulbu ile maksimum 1,5 ton güvenle taşınabilmektedir.

Panels are carried with the help of the Rapido Crane Hook. At least two crane hooks must be connected to the formwork that will be carried. The connection of the crane hooks to the panels and the safety pins must be checked. A maximum load of 1,5 ton can be carried with two crane hooks.

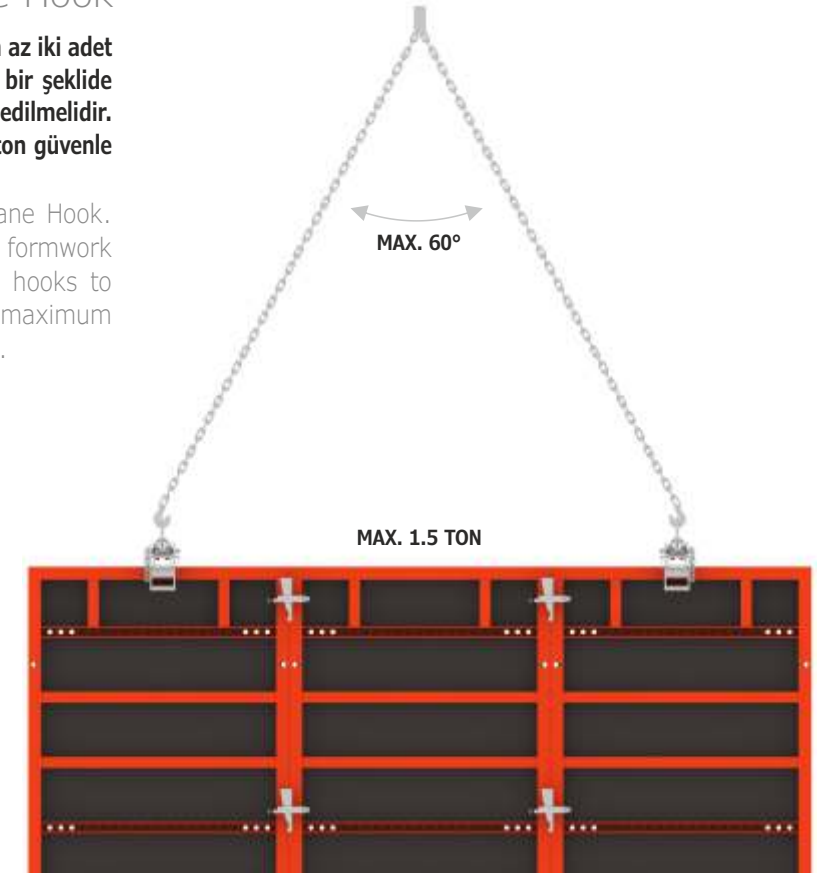

## Dik Açılı Köşe Detayı / Right-Angled Corner Detail

Standart paneller yardımıyla farklı kalınlıktaki perdelerin dik açılı köşelerini çözmek oldukça basittir.

With the help of standard panels it is quite simple to adjust the formwork to suit right-angled wall corners of different thicknesses.

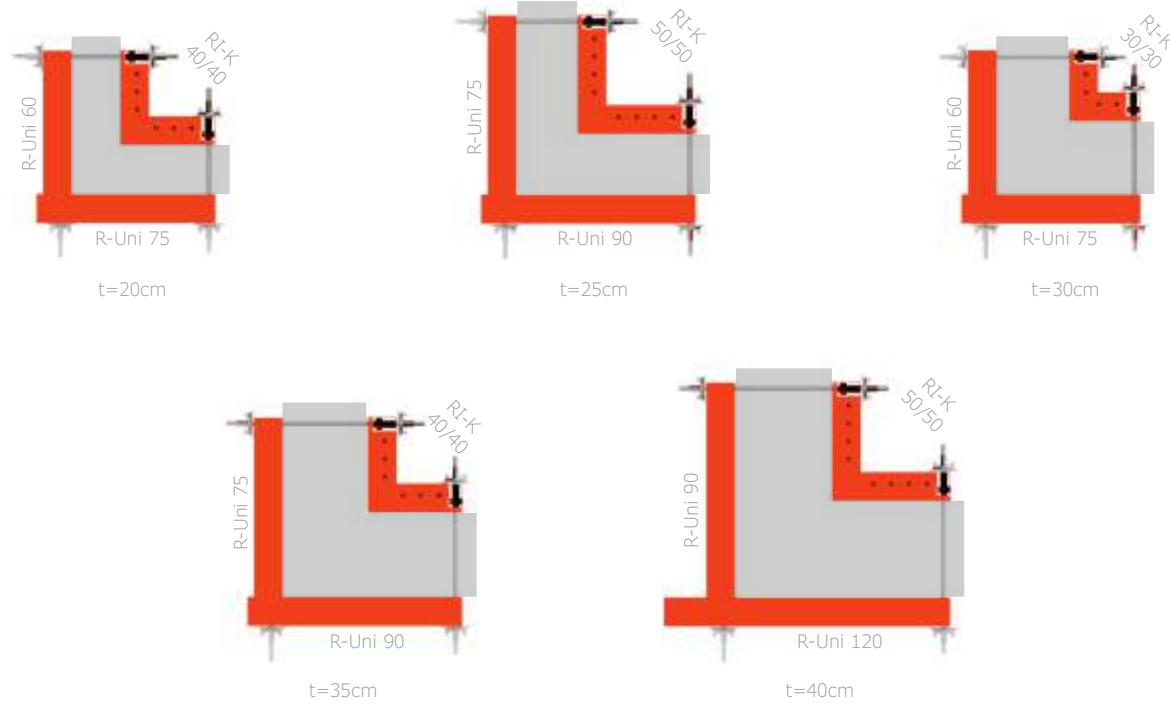

## T Bağlantı Detayı / T Connection Detail

Standart paneller ve dolgu yardımıyla farklı kalınlıktaki perdelerin T bağlantı detaylarını çözmek oldukça kolaydır.

With the help of standard panels and filling it is quite simple to adjust the formwork to suit T-shaped walls of different thicknesses.

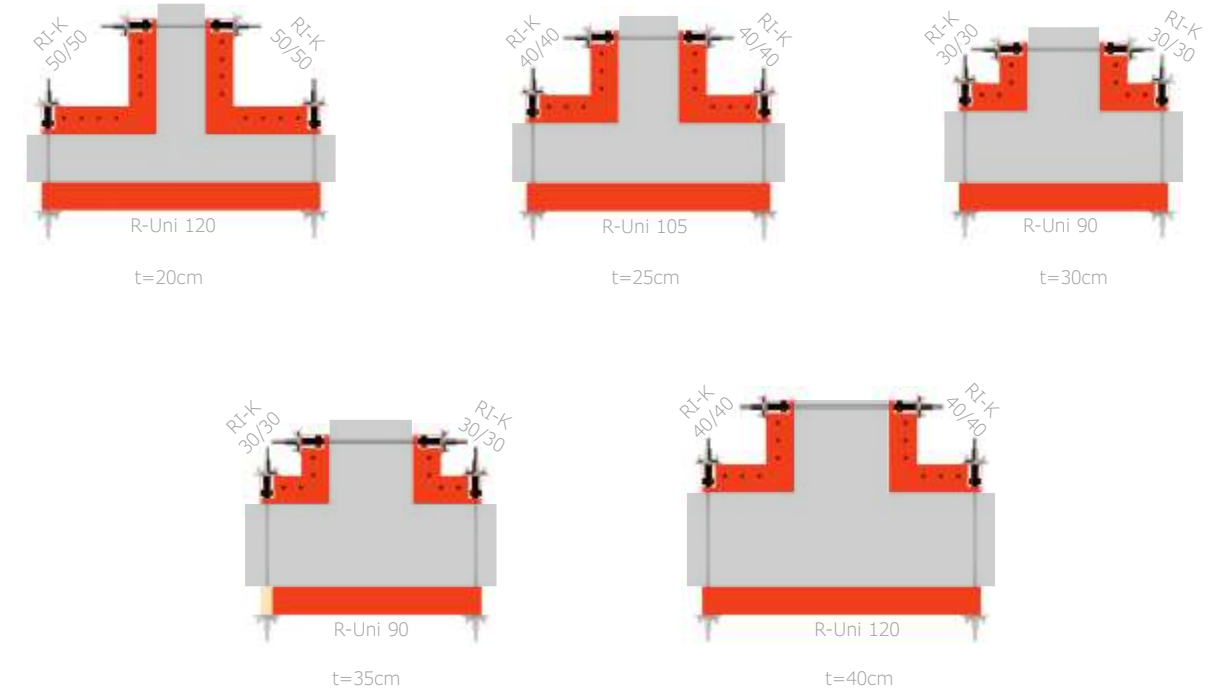

### Mafsallı Köşe Detayı / Articulated Corner Detail

Mafsallı iç köşe ve özel dış köşe paneller yardımıyla farklı açılara sahip perde köşe kalıplarını oluşturmak mümkündür. With the help of rapido articulated panel IC and customized external corner panel formwork can be adjusted to suit wall corners of different angles.

#### Özel Açılı Dış Köşe Customized External Corner



### Alın Kapama Detayı / Stop-End Detail

Rapido panel kalıplarda perde alınlarını farklı yöntemlerle çözmek mümkündür. It is possible to close the wall ends with different methods in Rapido panel formwork.



**Rapido Dış Köşe kullanarak**  
Using Rapido External Corner Panel

**Rapido Köşe Birleştirme Elemanı Kullanarak**  
Using Rapido Corner Connection





### Rapido Dairesel Perde / Rapido Circular Wall

Rapido panel kalıplarla dairesel formlu beton dökmek mümkündür. Bunun için konik ahşap dolgulara ihtiyaç vardır. İmalatı yapılacak olan dairesel perdenin çapına uygun ölçüde seçilen düz yüzeyli paneller ve bu paneller arasında projeye uygun özel olarak kesilmiş konik ahşap dolgular yardımıyla kırıklı dairesel form rahatlıkla oluşturulabilir.

It is possible to cast circular structures using Rapido panel formwork. To execute this job, it is also necessary to have a conical wood filling. Panel sizes are chosen according to the diameter of the circular structure and conical wood fillings are cut in a shape to suit the project, then they are placed between the panels. This way, a plynagonal circular form can be easily achieved.

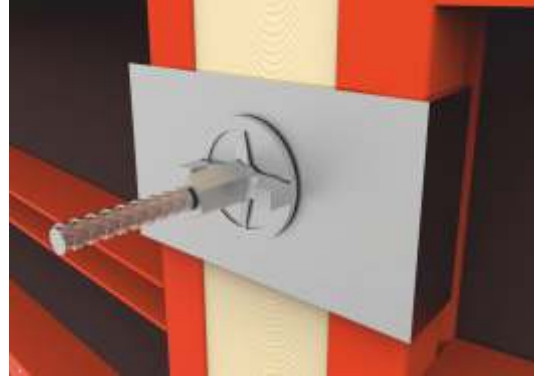

Özel Tie-Rod Aynası  
Customized Tie-Rod Plate

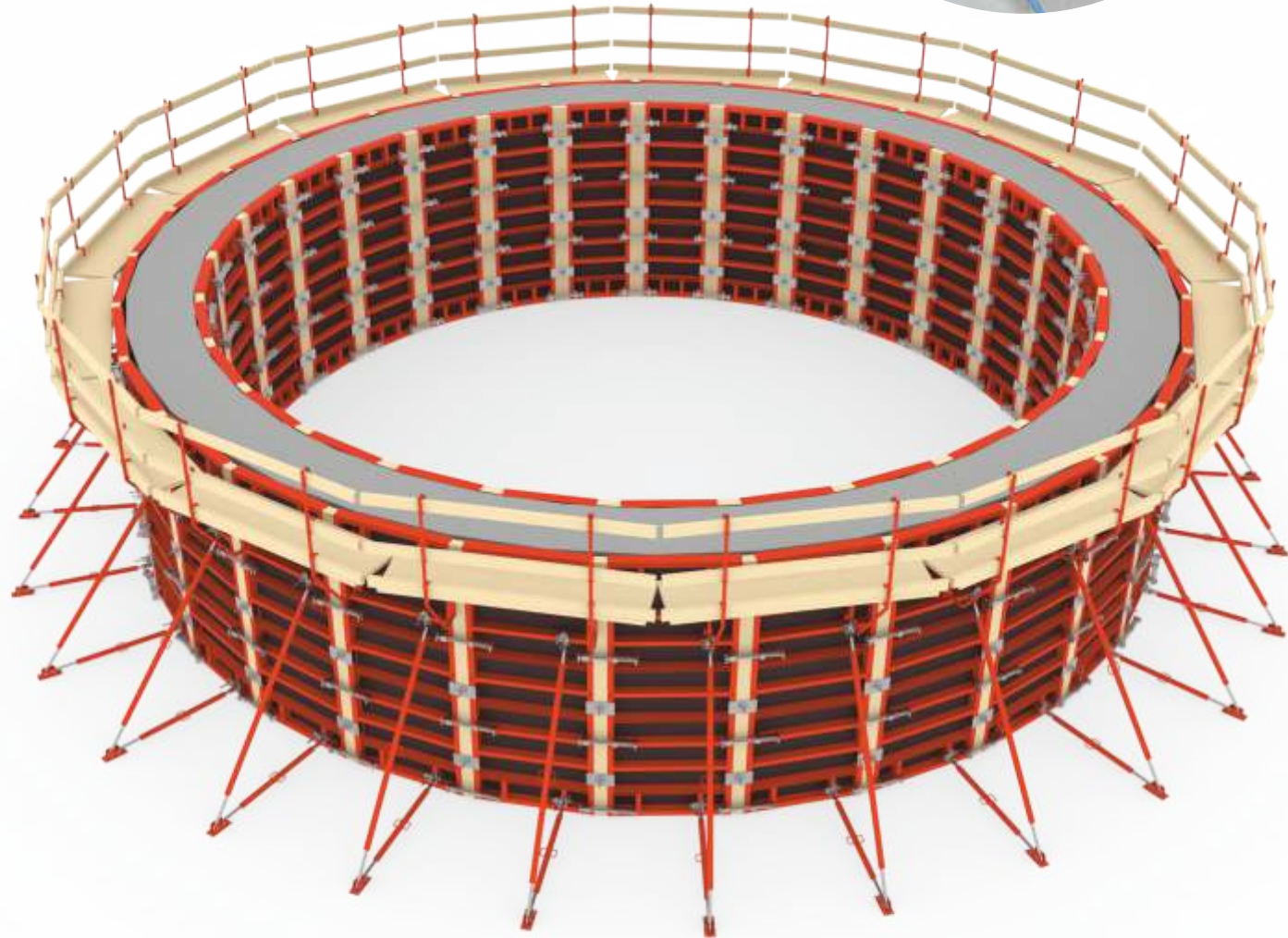

## RAPIDO / MEKANİZMALI İÇ KÖŞE SİSTEMİ

Mekanizmalı iç köşe paneller, çekirdek perde kalıpları için özel olarak tasarlanmıştır. Perde içerisine yerleştirilen kalıbın, demonte edilmeden küçültülüp büyütülmesini sağlar. Özel tasarımı sayesinde bu işlemlerin yapılması oldukça kolaydır. Kalıbın biten imalat sonrasında yerinden bir bütün halinde vinç ile kaldırılıp yeni yerine taşınması ve betona hazır hale getirilmesi çok kısa süreceği için zamandan ve işçilikten tasarruf sağlar.

## RAPIDO / STRIPPING CORNER SYSTEM

Rapido Stripping Corner is a system designed especially for core walls. The system that consists of four stripping corner panels can expand and contract mechanically without the use of a crane. Only one worker is enough to expand the system or contract it saving plenty of time and labor cost. The mechanism developed by Özler makes the operation fast and safe.

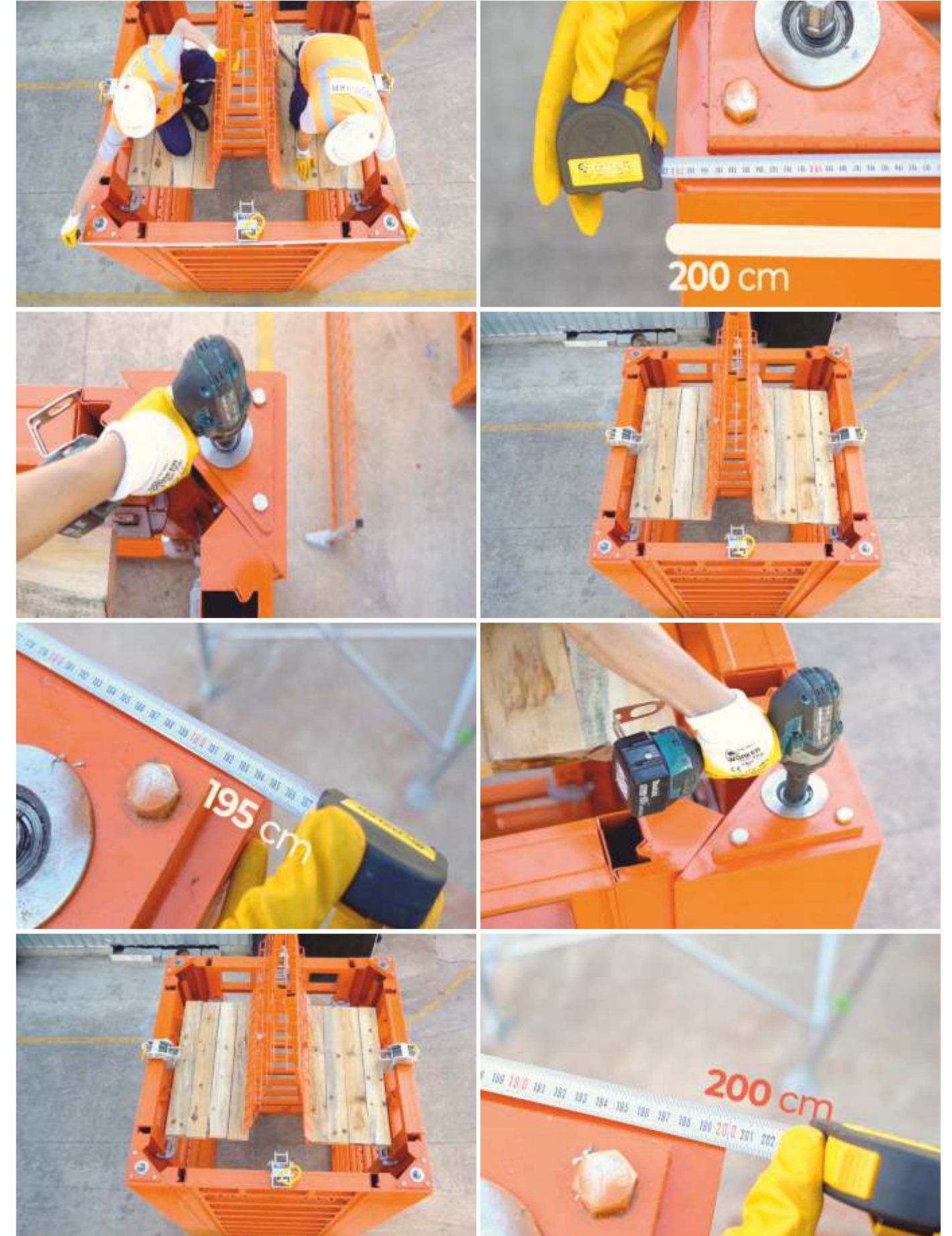
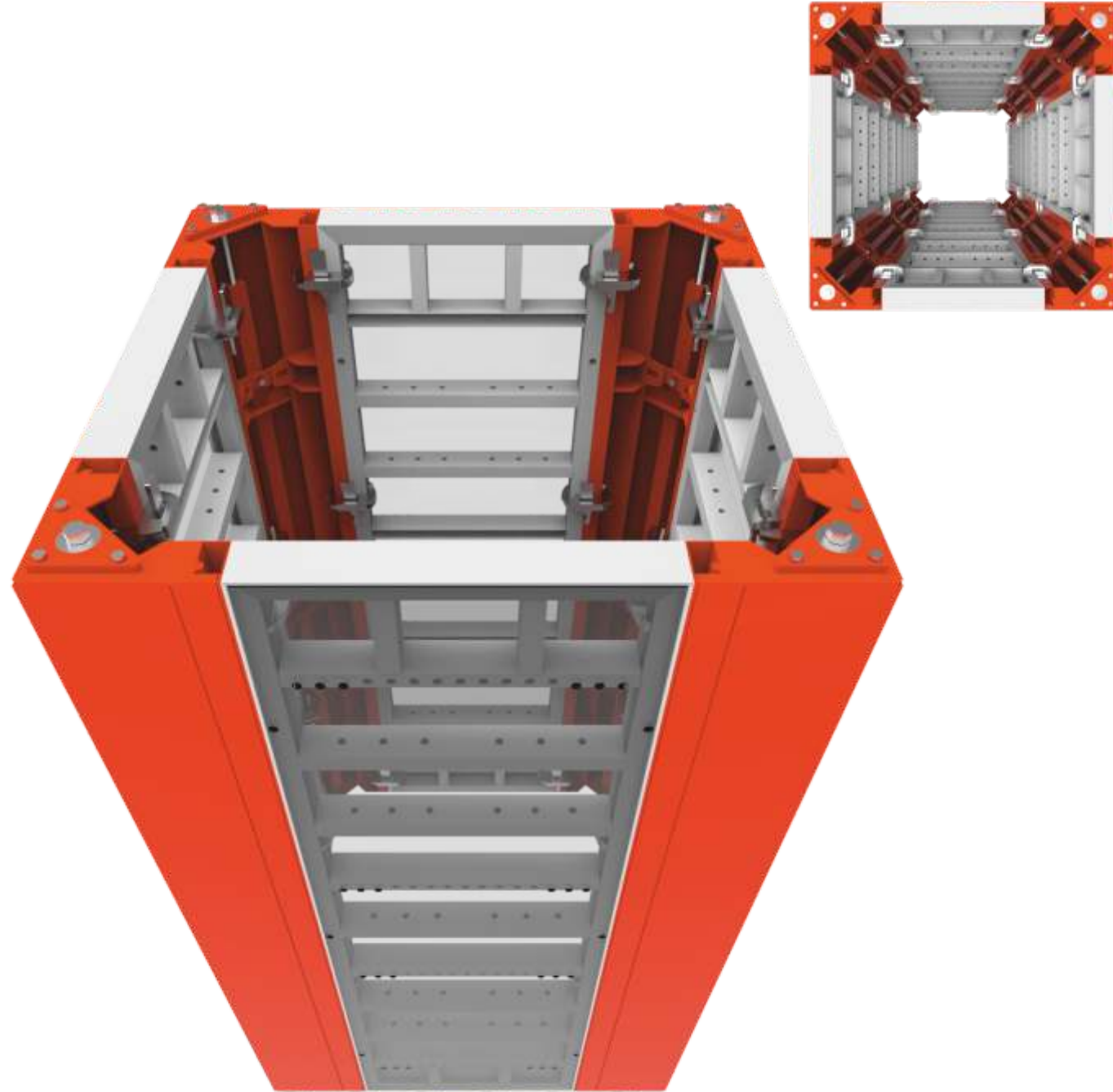

## STEELFORM / SAC YÜZEYLİ KALIP SİSTEMİ

STEELFORM tasarıma bağlı olarak hem vinç hem de el ile taşınan, çelik çerçevesi, sac yüzeyle kalıp sistemidir. Sistemin ana çerçevesinde Welser profil tarafından dizayn edilmiş, burulmaya karşı mukavemet değeri yüksek, özel şekillendirilmiş S355 veya S420 çelik profil kullanılmaktadır. Steelform kalıp sistemi Rapido ve Rapid panel kalıp sistemleri ile uyumludur. Steelform kalıp sistemi projenin ihtiyacına göre istenilen yüksekliğe ve maksimum taze beton basıncına göre dizayn edilebilir. Üretimlerimizde robotik kesme, delme ve kaynak prosesleri uygulanmaktadır. Paneller fırın boya işlemine tabi tutulmadan önce kumlama yapılarak yüzeyindeki kimyasal yağlardan arındırılır. Ayrıca talep halinde ürünlerimiz TS 914 EN ISO 1461 standartlarına göre daldırma galvaniz kaplanabilir.

## STEELFORM / STEEL SURFACE FORMWORK SYSTEM

STEELFORM is a steel frame, steel surfaced formwork system, which can be carried by crane or manually depending on the design. In the main frame of the system, specially shaped S355 or S420 steel profile with high torsional resistance value designed by Welser profile is used. STEELFORM formwork system is compatible with RAPIDO and RAPID panel formwork systems. Steelform formwork system can be designed according to the height and maximum fresh concrete pressure according to the needs of the project. Robotic cutting, drilling and welding processes are applied in our production. The steel products are cleaned with sandblasting before oven painting because of the industrial chemical oil. Upon request, our products can be hot dip galvanized according to TS 914 EN ISO 1461 standards.



## Dairesel Pano Circular Panel

KOD CODE	BOYUT cm SIZE cm	AĞIRLIK kg WEIGHT kg
103001005	Ø30×050	19,00
103004005	Ø30×100	43,00
103006005	Ø30×150	65,00
103008005	Ø30×300	120,00
103101005	Ø40×050	23,00
103104005	Ø40×100	50,00
103106005	Ø40×150	74,00
103108005	Ø40×300	138,00
103201005	Ø50×050	26,00
103204005	Ø50×100	57,00
103206005	Ø50×150	84,00
103208005	Ø50×300	158,00
103301005	Ø60×050	29,00
103304005	Ø60×100	63,00
103306005	Ø60×150	93,00
103308005	Ø60×300	177,00
103401005	Ø70×050	33,00
103404005	Ø70×100	69,00
103406005	Ø70×150	101,00
103408005	Ø70×300	195,00



KOD CODE	BOYUT cm SIZE cm	AĞIRLIK kg WEIGHT kg
103501005	Ø80×050	35,00
103504005	Ø80×100	76,00
103506005	Ø80×150	111,00
103508005	Ø80×300	215,00
103601005	Ø90×050	39,00
103604005	Ø90×100	83,00
103606005	Ø90×150	120,00
103608005	Ø90×300	233,00
103701005	Ø100×050	42,00
103704005	Ø100×100	90,00
103706005	Ø100×150	130,00
103708005	Ø100×300	253,00
103801005	Ø110×050	45,00
103804005	Ø110×100	96,00
103806005	Ø110×150	138,00
103808005	Ø110×300	272,00
103901005	Ø120×050	49,00
103904005	Ø120×100	102,00
103906005	Ø120×150	147,00
103908005	Ø120×300	291,00



**Rapido Kolon Kalıbı / Rapido Column Formwork**

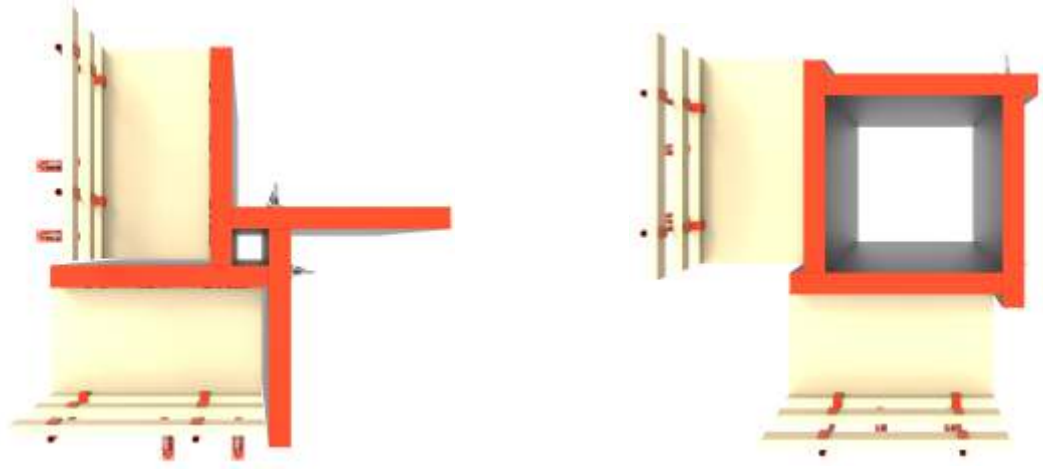

Rapido-Uni 120 cm paneller ile minimum 20\*20 cm, maksimum 105\*105 cm arasında kalıbı kendi içinde ayarlamak mümkündür.  
Columns with dimensions 20\*20cm up to 105\*105 cm can be casted using Rapido-Uni panels 120.

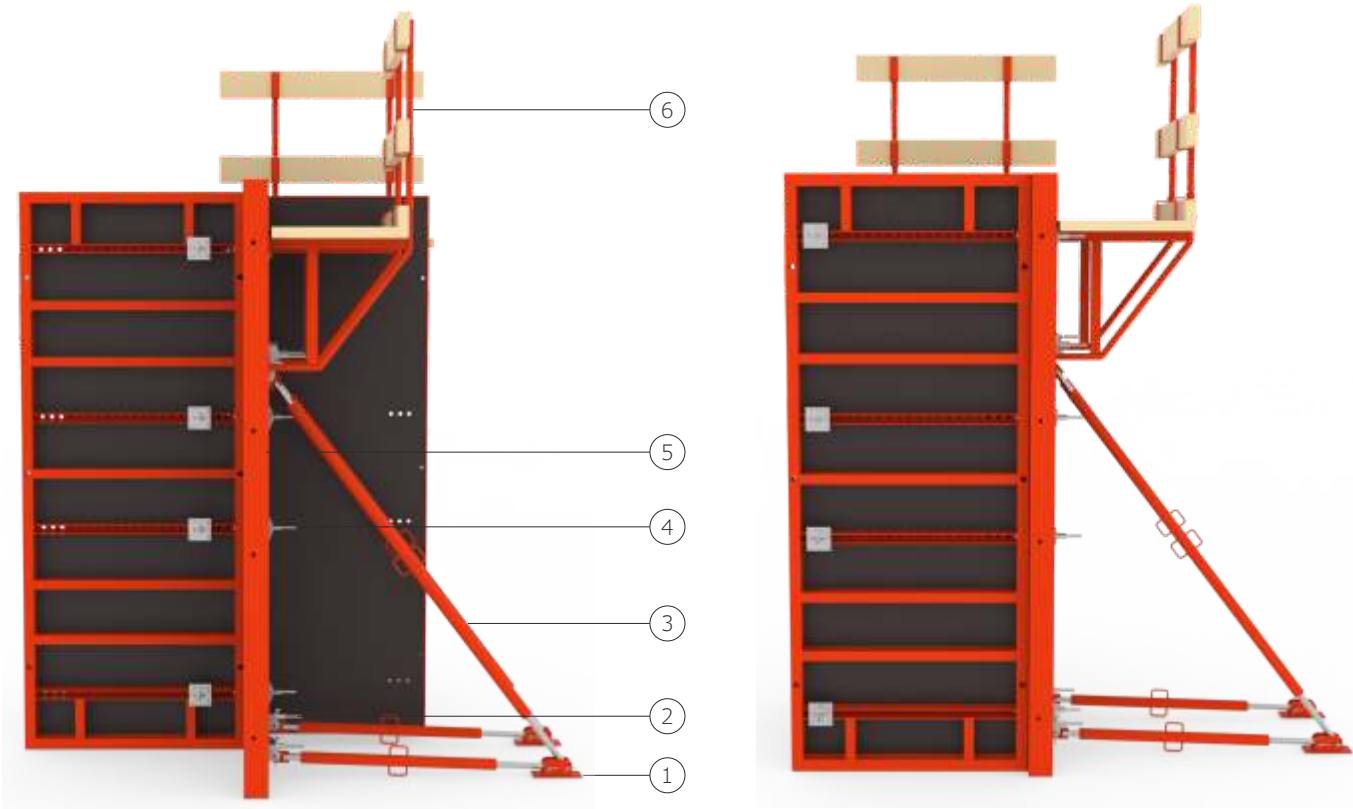

- 1 - Payanda Tabanı Çiftli / Base Plate Double
- 2 - Rapido Payanda Kafası + Somun / Rapido Push Pull Prop Head + Nut
- 3 - Payanda / Push Pull Prop
- 4 - Rapido Köşe Birleştirme Elemanı + Somun + Ayna / Rapido Corner Connector + Nut + Plate
- 5 - Rapido-Uni Panel / Rapido-Uni Panel
- 6 - Rapido Çalışma Konsolu / Rapido Bracket



**Rapido Köşe Birleştirme Detayı**  
Rapido Corner Connection Detail

Rapido-Uni panellerde kullanılan 5 cm de bir delinmiş perfore profiller sayesinde her ebat perde ve kolon kalıbı kolayca ayarlanabilir.

Thanks to the perforated profile with a hole every 5 cm, panels are adjusted to cast columns and shear walls of any dimensions desired.



## Rapido-Uni Panel

Rapido-Uni Panel

KOD CODE	BOYUT cm SIZE cm	AĞIRLIK kg WEIGHT kg
200602005	045*090	36,50
200603005	045*120	45,90
200604005	045*150	55,20
200608005	045*270	92,80
200609005	045*300	102,20
200610005	045*330	111,60
200702005	060*090	43,10
200703005	060*120	54,20
200704005	060*150	65,20
200708005	060*270	109,50
200709005	060*300	120,50
200710005	060*330	131,60
202502005	075*090	51,20
202503005	075*120	63,90
202504005	075*150	76,60
202508005	075*270	127,60
202509005	075*300	140,30
202510005	075*330	153,00
200802005	090*090	59,20
200803005	090*120	73,60
200804005	090*150	88,10
200808005	090*270	145,70
200809005	090*300	160,20
200810005	090*330	174,60
202402005	105*090	65,80
202403005	105*120	81,90
202404005	105*150	98,00
202408005	105*270	162,4
202409005	105*300	178,5
202410005	105*330	194,6
200902005	120*090	72,40
200903005	120*120	90,20
200904005	120*150	108,00
200908005	120*270	179,10
200909005	120*300	196,80
200910005	120*330	214,60

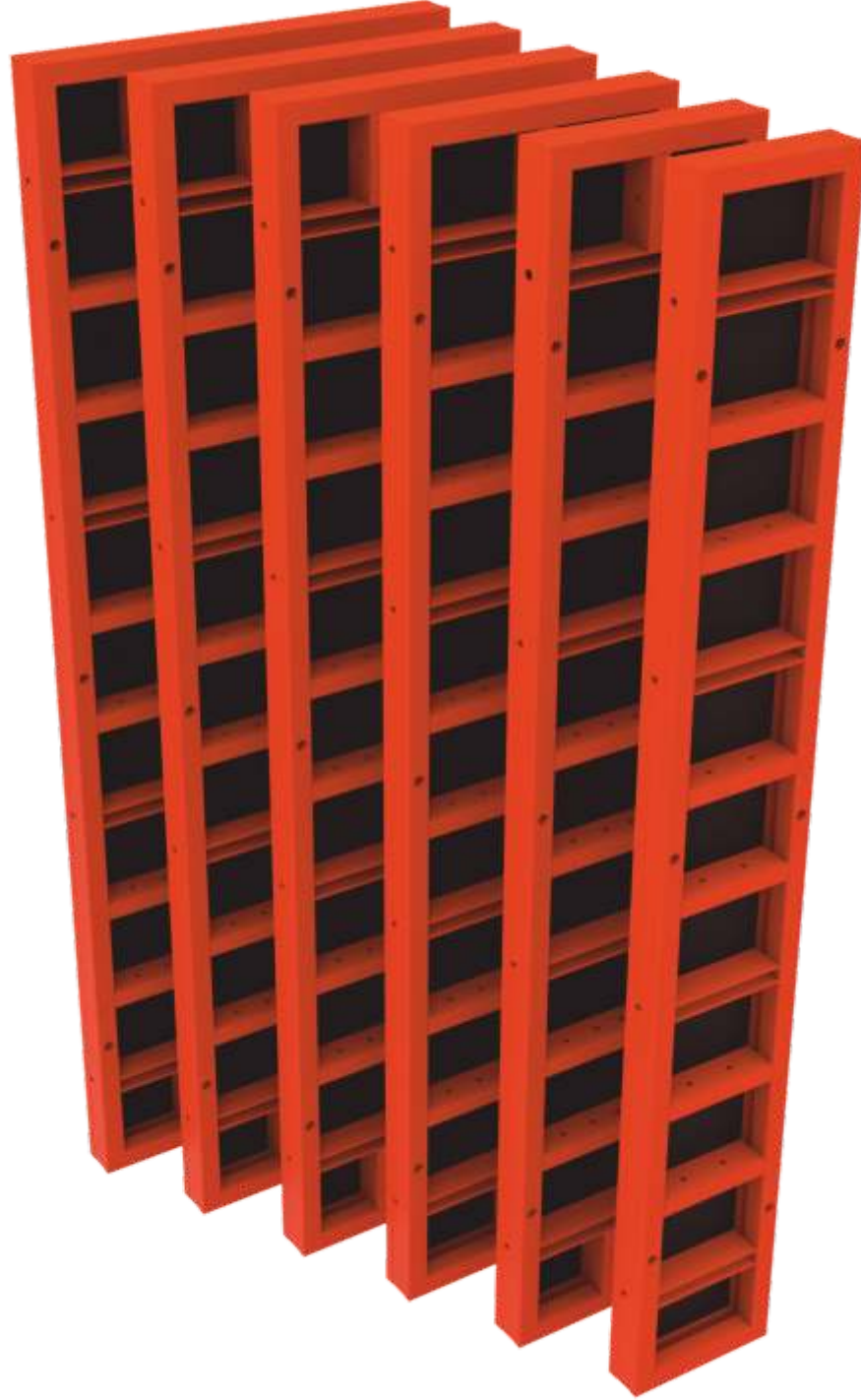

## Rapido İç Köşe

Rapido Internal Corner

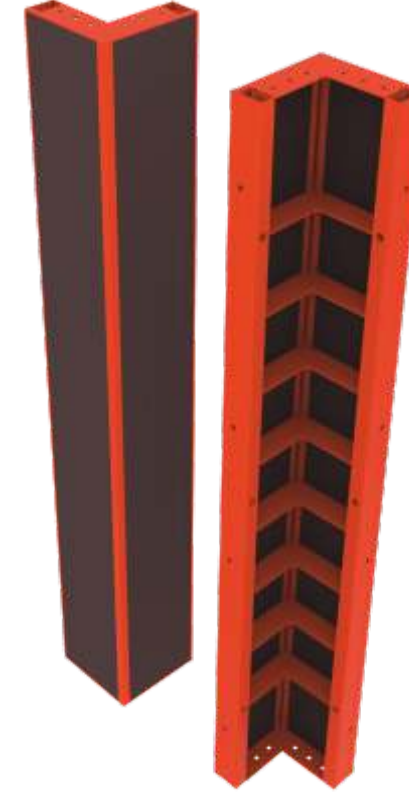

KOD CODE	BOYUT cm SIZE cm	AĞIRLIK kg WEIGHT kg
201002005	030*030*090	36,00
201003005	030*030*120	47,00
201004005	030*030*150	58,10
201008005	030*030*270	102,60
201009005	030*030*300	113,70
201010005	030*030*330	124,90
201102005	040*040*090	43,20
201103005	040*040*120	56,50
201104005	040*040*150	69,80
201108005	040*040*270	122,90
201109005	040*040*300	136,20
201110005	040*040*330	149,50
201202005	050*050*090	50,50
201203005	050*050*120	66,00
201204005	050*050*150	81,50
201208005	050*050*270	143,20
201209005	050*050*300	158,70
201210005	050*050*330	174,10

## Rapido Mafsallı İç Köşe

Rapido Articulated IC



KOD CODE	BOYUT cm SIZE cm	AĞIRLIK kg WEIGHT kg
201002105	030*030*090	40,50
201003105	030*030*120	54,40
201004105	030*030*150	65,30
201008105	030*030*270	117,00
201009105	030*030*300	129,50
201010105	030*030*330	143,40
201102105	040*040*090	48,20
201103105	040*040*120	63,10
201104105	040*040*150	78,00
201108105	040*040*270	139,50
201109105	040*040*300	153,20
201110105	040*040*330	168,00
201202105	050*050*090	56,50
201203105	050*050*120	73,80
201204105	050*050*150	86,20
201208105	050*050*270	159,60
201209105	050*050*300	176,40
201210105	050*050*330	193,00

KOD CODE	BOYUT cm SIZE cm	AĞIRLIK kg WEIGHT kg
201302005	090	10,80
201303005	120	14,40
201304005	150	18,00
201308005	270	32,40
201309005	300	36,00
201310005	330	39,60



**Rapido Dış Köşe**  
Rapido External Corner

KOD CODE	BOYUT cm SIZE cm	AĞIRLIK kg WEIGHT kg
203004005	40*40*330	358,00



**Rapido Mekanizmalı Köşe**  
Rapido Stripping Corner

KOD CODE	BOYUT cm SIZE cm	AĞIRLIK kg WEIGHT kg
201401003		3,30



**Rapido Kilit - Standart**  
Rapido Lock - Standard

KOD CODE	BOYUT cm SIZE cm	AĞIRLIK kg WEIGHT kg
201402003		5,40



**Rapido Kilit - Ayarlanabilir**  
Rapido Lock - Adjustable

KOD CODE	BOYUT cm SIZE cm	AĞIRLIK kg WEIGHT kg
201504005	050	4,90
201501005	075	7,60
201502005	100	9,80
201503005	150	15,20



**Panel Kalıp Destek Kuşağı**  
Panel Formwork Support Waler

KOD CODE	BOYUT cm SIZE cm	AĞIRLIK kg WEIGHT kg
201601003		0,70



**Destek Kuşağı Bağlama Elemanı**  
Support Waler Connector

KOD CODE	BOYUT cm SIZE cm	AĞIRLIK kg WEIGHT kg
201701003		0,60



**Rapido Köşe Birleştirme Elemanı**  
Rapido Corner Connector

KOD CODE	BOYUT cm SIZE cm	AĞIRLIK kg WEIGHT kg
201801003		1,80

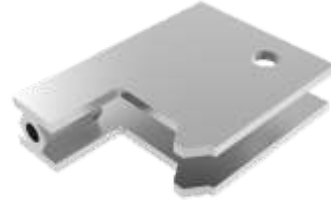

**Rapido Alın Bağlama Elemanı**  
Rapido End Plate

KOD CODE	BOYUT cm SIZE cm	AĞIRLIK kg WEIGHT kg
101700000	050	0,75
101701000	100	1,50
101702000	120	1,80
101703000	150	2,20
101704000	200	3,00
101705000	250	3,75
101706000	300	4,50
101707000	400	6,00
101708000	500	7,50
101709000	600	9,00



**Dywidag Tie-Rod Ø15/17**  
Dywidag Tie-Rod Ø15/17

KOD CODE	BOYUT cm SIZE cm	AĞIRLIK kg WEIGHT kg
101710003		0,50



**Tie-Rod Somunu Ø90**  
Tie-Rod Nut Ø90

KOD CODE	BOYUT mm SIZE mm	AĞIRLIK kg WEIGHT kg
101711003	120*120	0,90



**Tie-Rod Aynası 8mm**  
Tie-Rod Plate 8mm

KOD CODE	BOYUT cm SIZE cm	AĞIRLIK kg WEIGHT kg
101801005	050	9,90
101802005	100	12,00
101803005	120	12,50
101804005	150	15,00
101805005	175	16,00
101806005	200	16,50
101807005	250	19,60
101808005	300	23,00

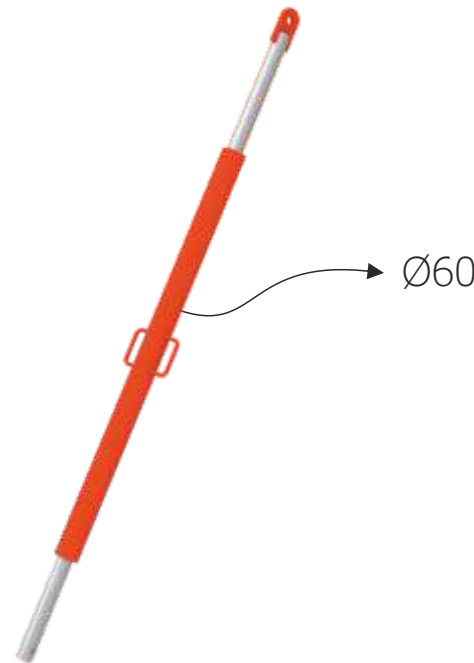

**Payanda Ø60**  
Push Pull Prop Ø60

KOD CODE	BOYUT cm SIZE cm	AĞIRLIK kg WEIGHT kg
101901005	300	45,00
101902005	400	49,10
101903005	600	66,70

**Payanda Ø76**  
Push Pull Prop Ø76

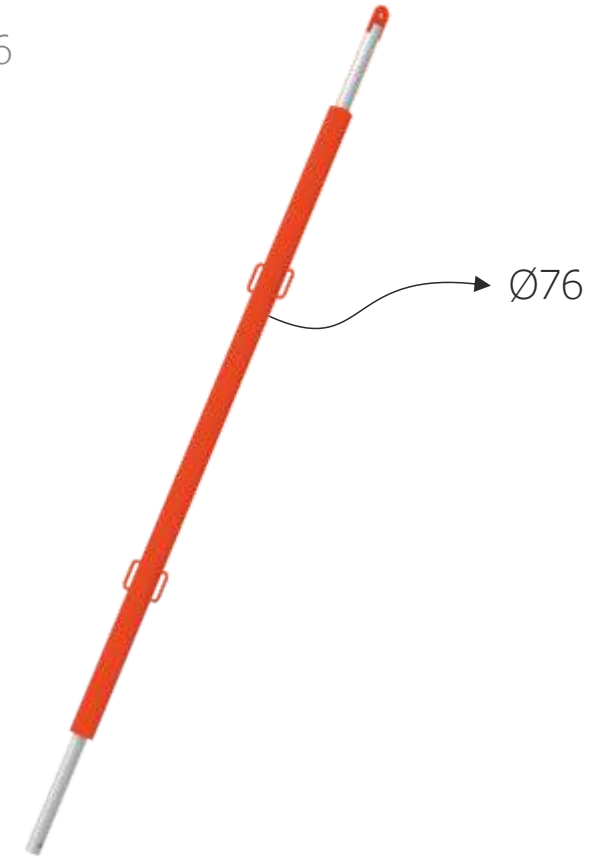

**Teleskopik Dev Payanda Ø102**  
Telescopic Push Pull Prop Ø102

KOD CODE	BOYUT cm SIZE cm	AĞIRLIK kg WEIGHT kg
101904005	650/1050	148,00

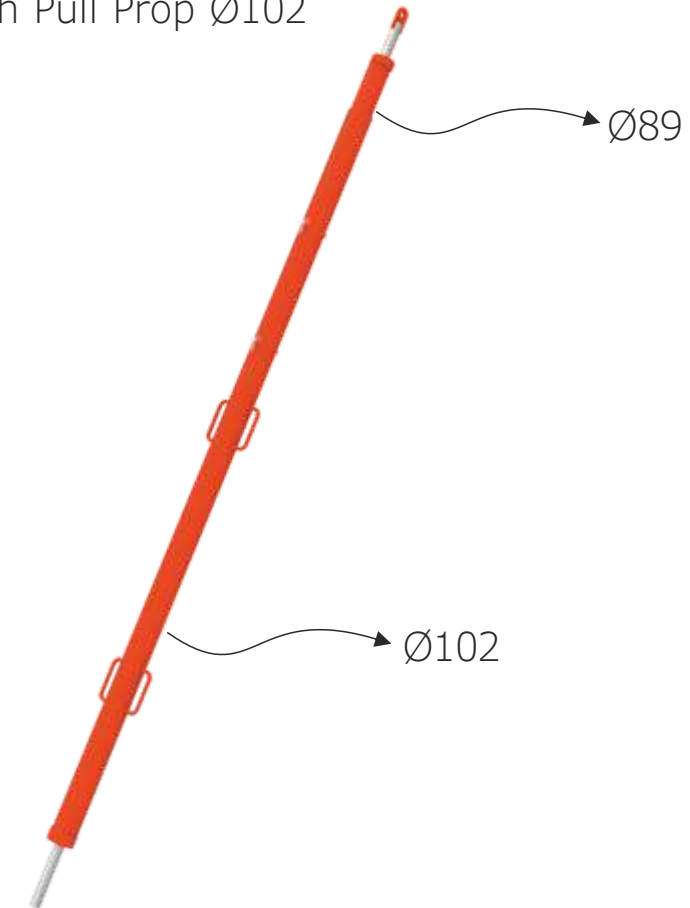

KOD CODE	BOYUT cm SIZE cm	AĞIRLIK kg WEIGHT kg
102101005		1,70



**Payanda Tabanı Tekli**  
Base Plate Single

KOD CODE	BOYUT cm SIZE cm	AĞIRLIK kg WEIGHT kg
102102005		2,70



**Payanda Tabanı Çiftli**  
Base Plate Double

KOD CODE	BOYUT cm SIZE cm	AĞIRLIK kg WEIGHT kg
202001003		3,20



**Rapido Payanda Kafası**  
Rapido Push Pull Prop Head

KOD CODE	BOYUT cm SIZE cm	AĞIRLIK kg WEIGHT kg
202101005		11,00



**Rapido Çalışma Konsolu**  
Rapido Bracket

KOD CODE	BOYUT cm SIZE cm	AĞIRLIK kg WEIGHT kg
202201003		8,30



**Rapido Vinç Kulbu**  
Rapido Crane Hook

KOD CODE	BOYUT cm SIZE cm	AĞIRLIK kg WEIGHT kg
232001005		4,00



**Rapido Zemin Sabitleme Elemanı**  
Rapido Bottom Fixer

KOD CODE	BOYUT mm SIZE mm	AĞIRLIK kg WEIGHT kg
H115P16080	16*80	0,15



**Pim ve Kopilya**  
Pin and Split Pin

KOD CODE	BOYUT mm SIZE mm	AĞIRLIK kg WEIGHT kg
H115C16060	16*60	0,10



**Civata ve Somun**  
Bolt and Nut

KOD CODE	BOYUT mm SIZE mm	AĞIRLIK kg WEIGHT kg
H115V14080	14*80	0,10
H115V14110	14*110	0,12



**Zemin Ankraj Vidası Multi-Monti**  
Multi-Monti Screw