

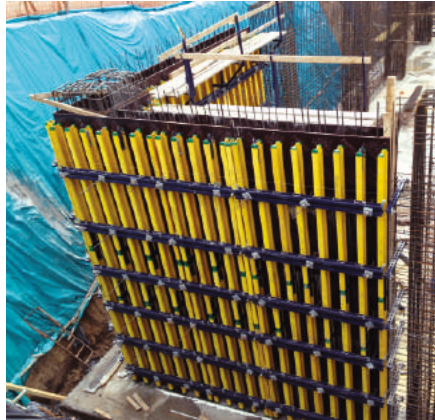

Your solution partner since 96

TIMBERFORM

H20 BEAM FORMWORK



TIMBERFORM / AHŞAP KİRİŞLİ KOLON VE PERDE KALIBI SİSTEMİ

Timberform vinç ile taşınan dikeyde H20 ahşap kirişler yatayda çelik perde kuşakları ve yüzeyinde plywood kaplı geniş yüzeyli perde ve kolon kalıbı sistemidir. Sistemin dikey yönünde kullanılan H20 ahşap kirişler EN 13377 standartlarına göre üretilmiştir. Sistem H20 ahşap kirişlerin tek ya da eklenerek kullanılması halinde her türlü yükseklığe göre ayarlanabilir. Tasarımlarımızda perde kalıplarında maksimum 50 kN/m², kolon kalıplarında maksimum 80 kN/m² taze beton basıncı dikkate alınır. Ayrıca dikey yöndeki H20 ahşap kirişlerin adetlerini arttırarak veya azaltarak, yatay yöndeki çelik perde kuşaklarının adetlerini arttırarak veya azaltarak yüksek beton basınçlarına ve döküm hızlarına göre sistemi dizayn etmek mümkündür. Üretimlerimizde robotik kesme, delme ve kaynak prosesleri uygulanmaktadır. Çelik ürünler fırın boya işlemine tabi tutulmadan önce kumlama yapılarak yüzeyindeki kimyasal yağlardan arındırılır. Ayrıca talep halinde ürünlerimiz TS 914 EN ISO 1461 standartlarına göre daldırma galvaniz kaplanabilir.

TIMBERFORM / COLUMN AND WALL FORMWORK SYSTEM

TIMBERFORM is a large area wall and column formwork system carried by Crane which is set with vertical H20 wooden beams, horizontal steel waler and plywood surfaced. H20 wooden beams are used in the vertical direction of the system are produced according to EN 13377 standards. The system can be adjusted to any height if the H20 wooden beams are used individually or added together. Our designs are in accordance with maximum 50 kN/m² fresh concrete pressure in walls and 80 kN/m² fresh concrete pressure in column. It is also possible to design the system according to high concrete pressures and casting speeds by increasing or decreasing the number of H20 wooden beams in the vertical direction and increasing or decreasing the number of steel walers in the horizontal direction. Robotic cutting, drilling and welding processes are applied in our production. The steel products are cleaned with sandblasting before oven painting because of the industrial chemical oil. Upon request, our products can be hot dip galvanized according to TS 914 EN ISO 1461 standards.

TIMBERFORM

H20 BEAM FORMWORK

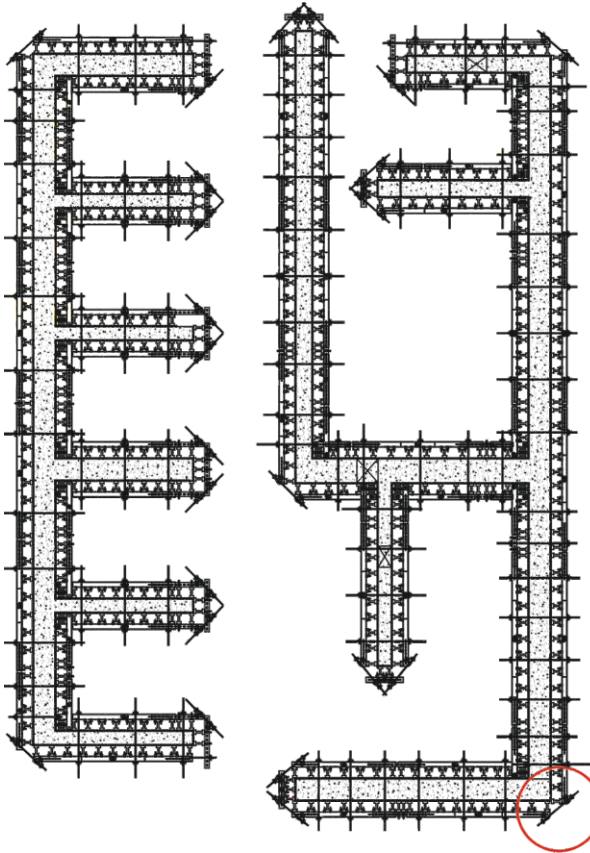

Wall formwork CAD plan

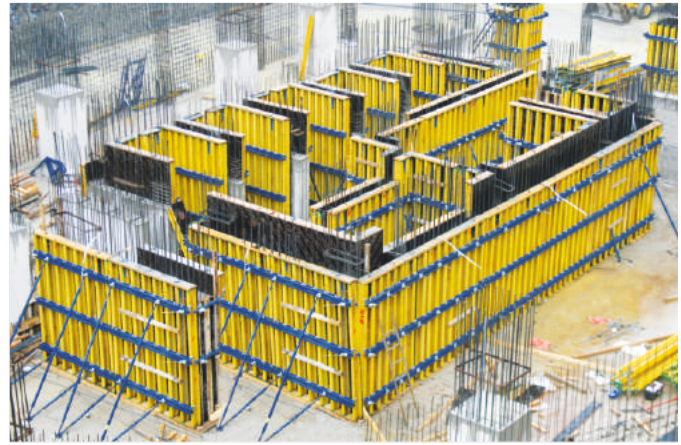

Wall formwork application

With timberform wall formwork system; right solution can be made for project by using standart panels.

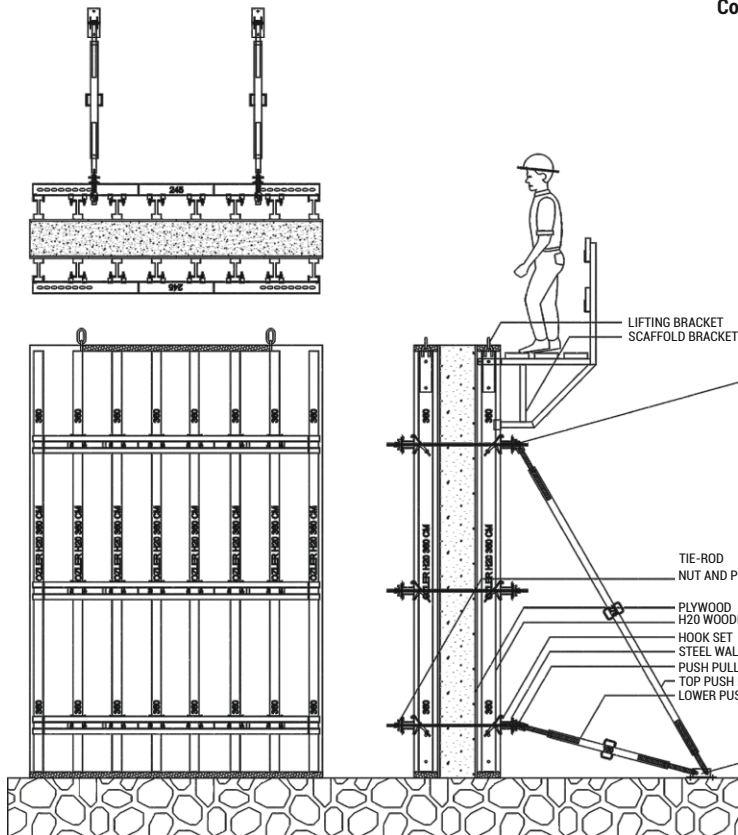
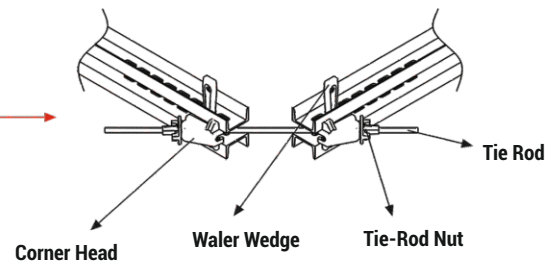

Timberform wall formwork panel typical plan, appearance and section

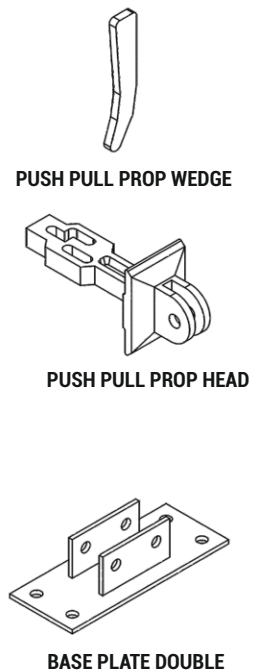

By using adjustable column waler, column formworks can be designed in a different measurement

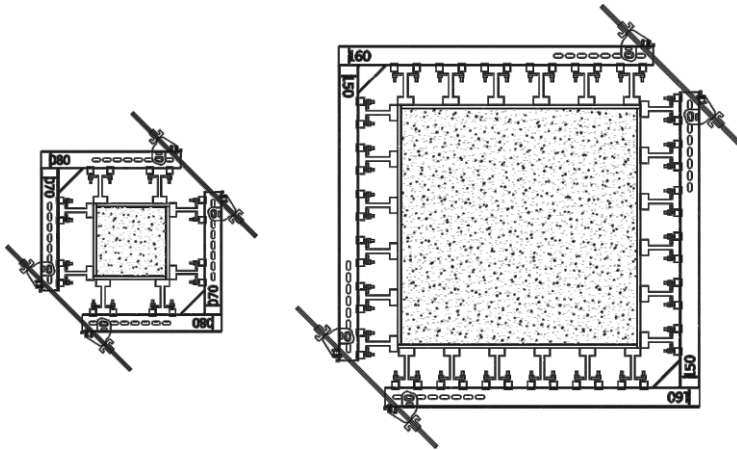

Fixed waler column application

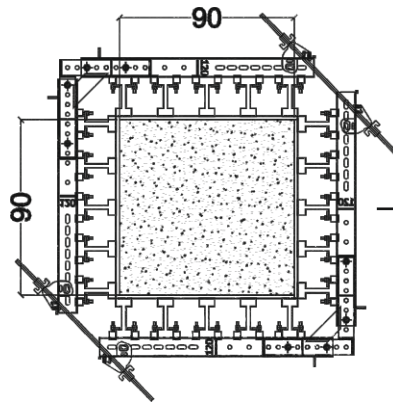
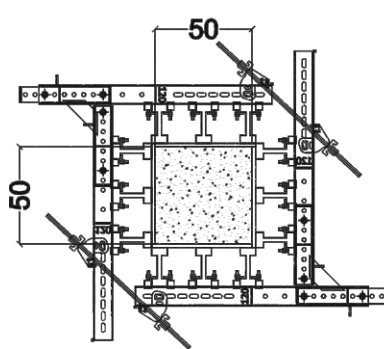

By using adjustable 120 column waler,
Column formworks can be use min
50/50 and max 90/90

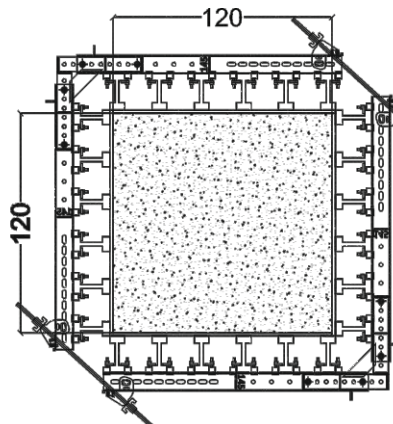
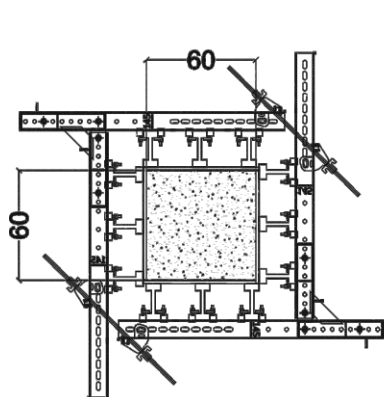

By using adjustable 145 column waler, Column
formworks can be use min 60/60 max 120/120

Adjustable column waler application

TIMBERFORM

H20 BEAM FORMWORK

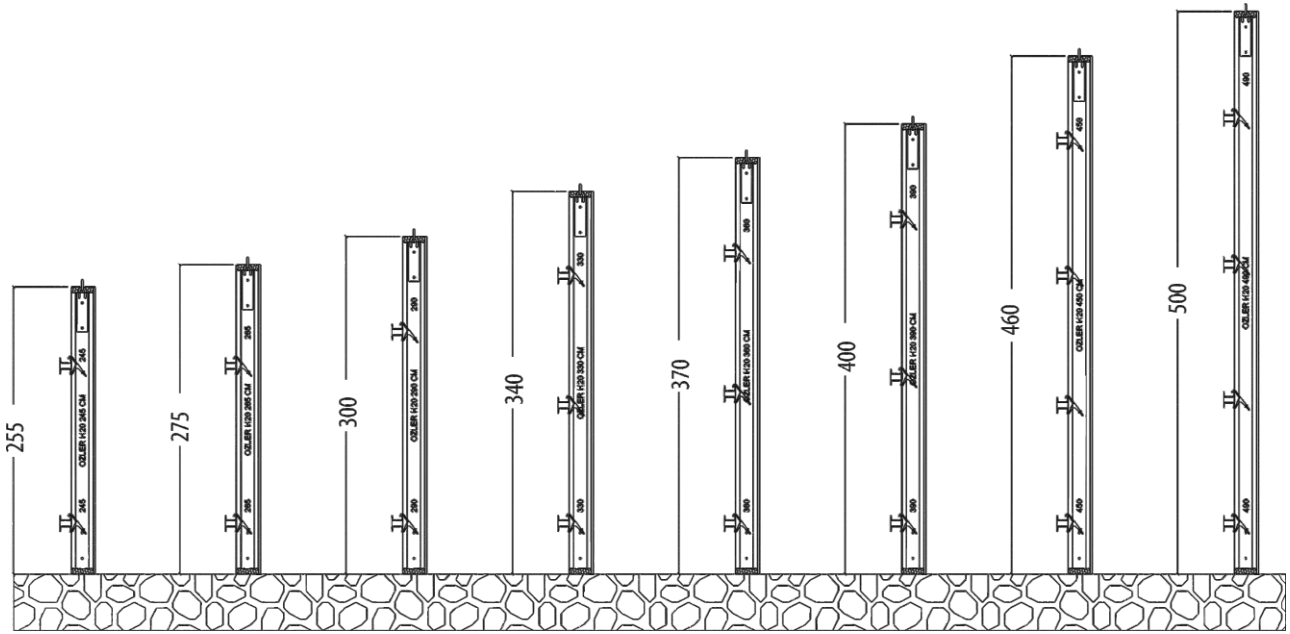

Typical Wall and column formwork section

Different heights of H20 can be desing for your project.

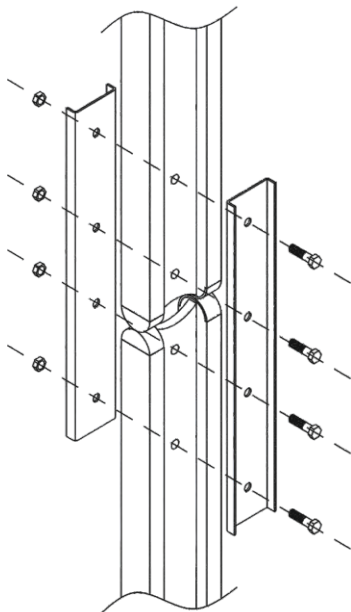

Except for standard H20 measurement; higher column and wall formwork panels can be made by using H20-H20 extensions

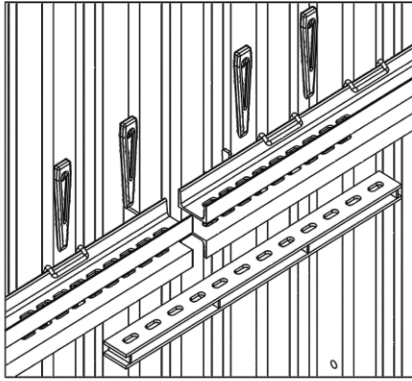

Timberform wall formwork panels can be larger with the help of water coupler and water wedge

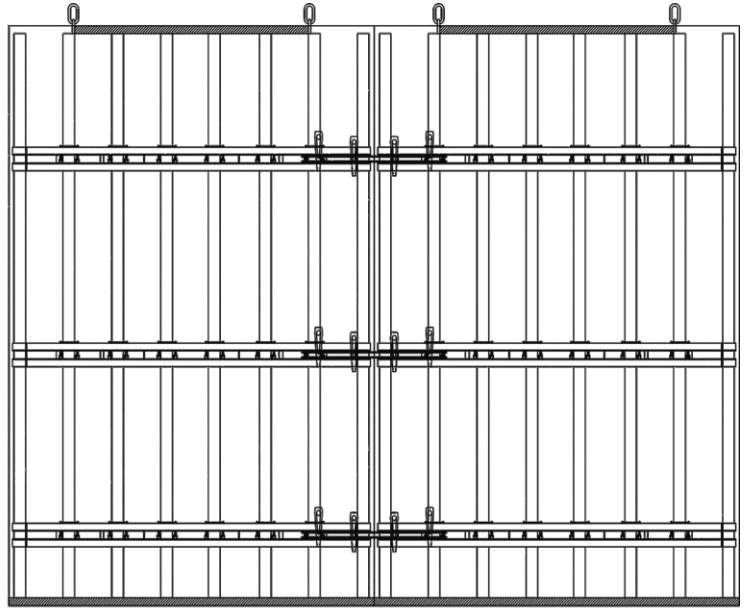

Details of Timberform wall formwork panel

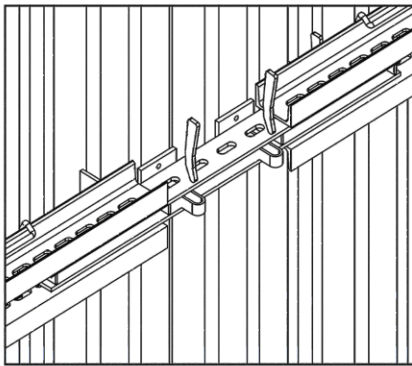

To Easy remove wall formwork in the shaft, beam clamp can put between panels and casting can be done

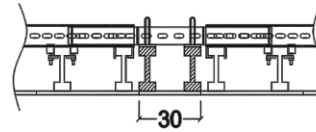

Maximum casting space to achieve with the waler coupler 99

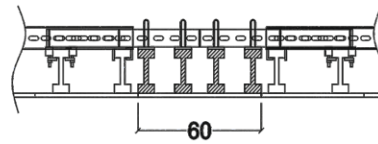

Maximum casting space to achieve with the waler coupler 149

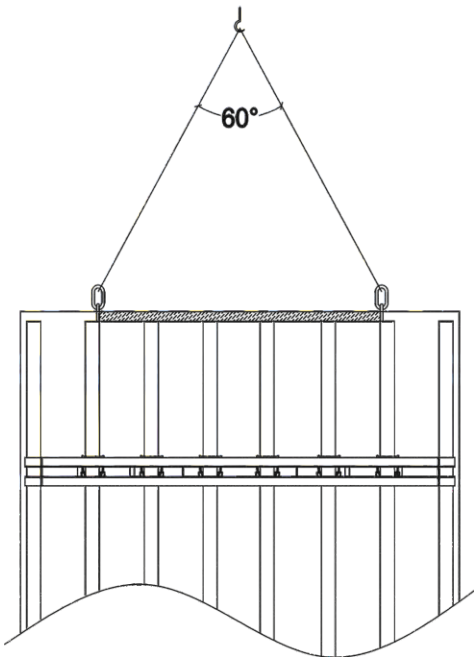

In Timberform formwork system, all the panels can be move safety both horizontal and vertical way due to lifting brackets connections by holding from two points

TIMBERFORM

H20 BEAM FORMWORK





TIMBERFORM

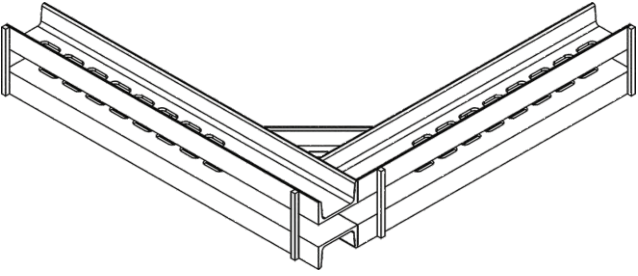
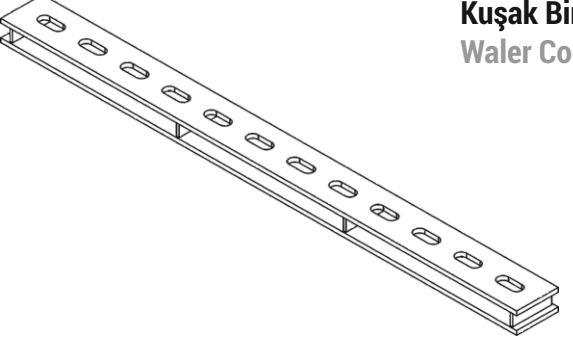
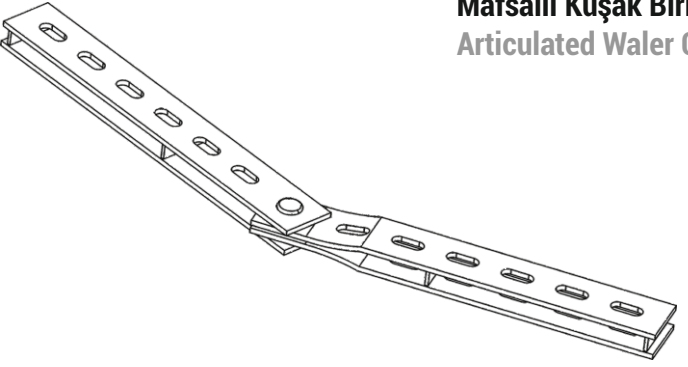

H20 BEAM FORMWORK

	AĞIRLIK WEIGHT KG	UZUNLUĞU LENGTH	ÜRÜN KODU CODE	
H20 Ahşap Kiriş H20 Wooden Beam	12,25	245	100104	
	13,25	265	100105	
	14,50	290	100106	
	16,50	330	100107	
	18,00	360	100108	
	19,50	390	100109	
	22,50	450	100110	
	24,50	490	100111	
	29,50	590	100112	
Plywood Plywood	31,00	1250*2500*18	100201	
	36,00	1250*2500*21	100202	
Çelik Perde Kuşağı Steel Waler	15,40	070	100301	
	20,90	095	100302	
	26,40	120	100303	
	31,90	145	100304	
	37,40	170	100305	
	42,90	195	100306	
	48,40	220	100307	
	53,90	245	100308	
	59,40	270	100309	
	64,90	295	100310	
	70,40	320	100311	
	75,90	345	100312	
	81,40	370	100313	
86,90	395	100314		
Köşe Kuşağı Corner Waler	Corner Size 50*50	17,60	019*016*045	100401
	Corner Size 50*75	23,10	019*016*070	100402
	Corner Size 75*75	28,60	019*041*070	100403
	Corner Size 75*100	34,10	019*041*095	100404
	Corner Size 100*100	39,60	019*066*095	100405
	Corner Size 100*125	45,10	019*066*120	100406
	Corner Size 125*125	50,60	019*091*120	100407

AĞIRLIK WEIGHT KG	UZUNLUĞU LENGTH	ÜRÜN KODU CODE	
12,25	245	100104	<p>Column Size 40*40 Column Size 50*50 Column Size 60*60 Column Size 70*70 Column Size 80*80 Column Size 90*90 Column Size 100*100 Column Size 110*110 Column Size 120*120</p> <p>Kolon Kuşağı Column Waler</p> 
13,25	265	100105	
14,50	290	100106	
16,50	330	100107	
18,00	360	100108	
19,50	390	100109	
22,50	450	100110	
24,50	490	100111	
29,50	590	100112	
26,40	120	100601	
31,90	145	100602	
37,40	170	100603	
42,90	195	100604	
4,50	049	100801	<p>Kuşak Birleştirme Elamanı Waler Coupler</p> 
9,50	099	100802	
13,50	149	100803	
13,00	65,65	100804	<p>Mafsallı Kuşak Birleştirme Articulated Waler Coupler</p> 

TIMBERFORM

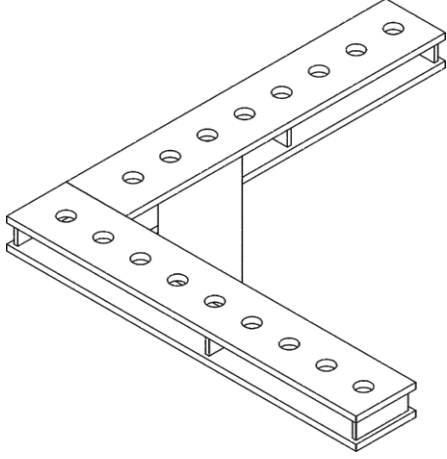
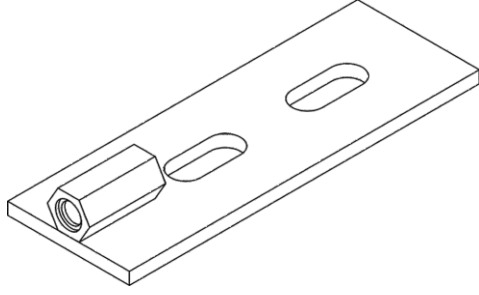
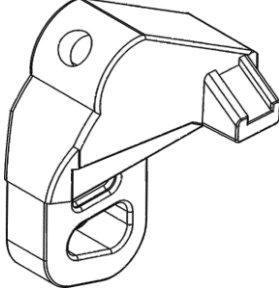
H20 BEAM FORMWORK

	AĞIRLIK WEIGHT KG	UZUNLUĞU LENGTH	ÜRÜN KODU CODE
Köşe Gönyesi - K Corner Coupler - K 	10,00		100805
Alın Bağlama Elmanı Stopend 	2,25		100901
Köşe Birleştirme Elmanı Corner Head 	2,70		101001
Kuşak Kaması Waler Wedge 	0,80		101101

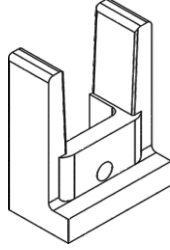
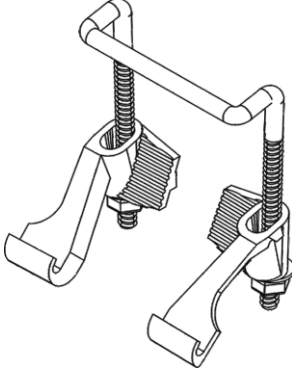
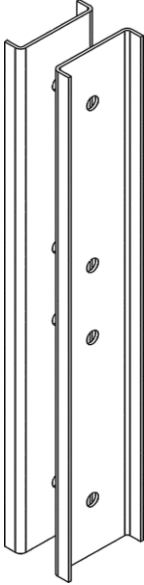
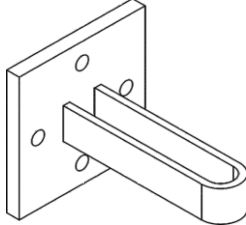
AĞIRLIK WEIGHT KG	UZUNLUĞU LENGTH	ÜRÜN KODU CODE	
0,70		101201	 <p>H20 Klips H20 Clips</p>
0,90		101301	 <p>H20 Bağlama Kancası Hook Set</p>
8,40		101401	 <p>H20-H20 Ekleme Elemanı H20-H20 Extension</p>
1,20		101501	 <p>Adaptör Beam Clamp</p>

TIMBERFORM

H20 BEAM FORMWORK

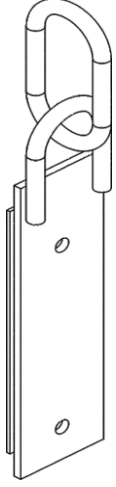
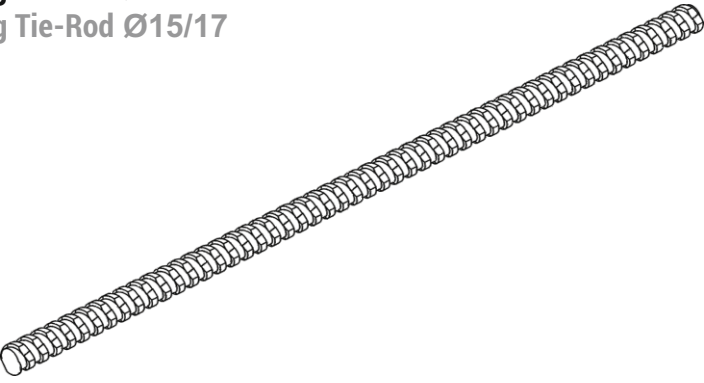
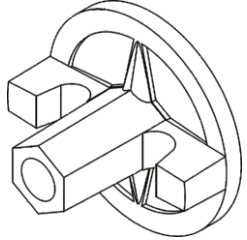
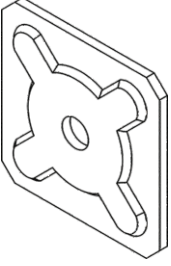

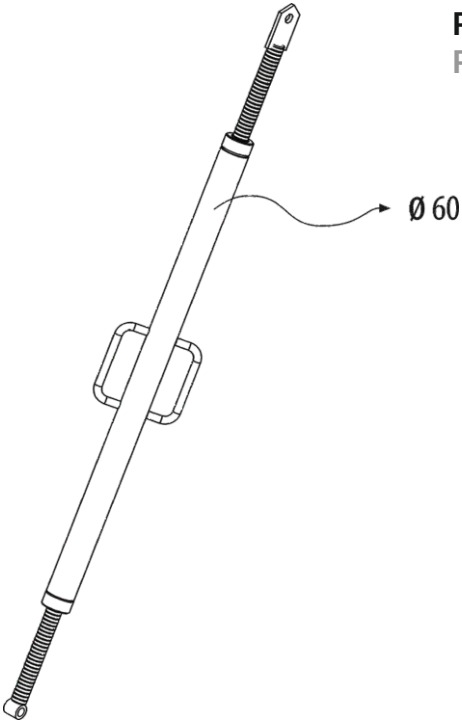
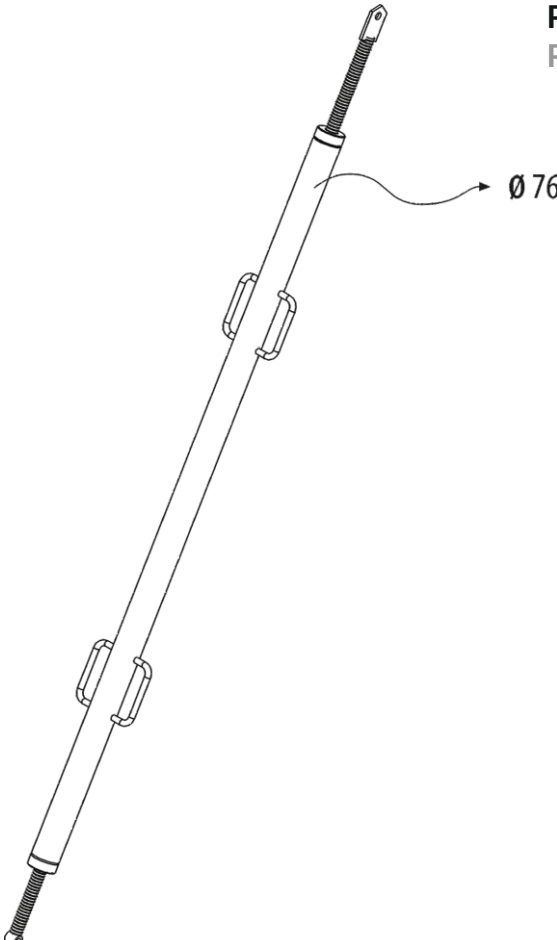
	AĞIRLIK WEIGHT KG	UZUNLUĞU LENGTH	ÜRÜN KODU CODE
Vinç Kulbu Lifting Bracket 	3,80		101601
Dywidag Tie-Rod Ø15/17 Dywidag Tie-Rod Ø15/17 	1,50 1,80 2,25 3,00 3,75 4,50 6,00 7,50 9,00	17*1000 17*1200 17*1500 17*2000 17*2500 17*3000 17*4000 17*5000 17*6000	101701 101702 101703 101704 101705 101706 101707 101708 101709
Tie-Rod Somunu Ø100 Tie-Rod Nut Ø100 	1,00		101710
Tie-Rod Aynası 8mm Tie-Rod Plate 8mm 	1,00		101711

AĞIRLIK WEIGHT KG	UZUNLUĞU LENGTH	ÜRÜN KODU CODE	
10,25	050	101801	 <p>Payanda 60 Push Pull Props 60</p>
12,50	100	101802	
13,25	120	101803	
14,50	150	101804	
15,50	175	101805	
16,50	200	101806	
19,75	250	101807	
22,75	300	101808	
40,15	300	101901	 <p>Payanda 76 Push Pull Props 76</p>
48,90	400	101902	
68,50	600	101903	

TIMBERFORM

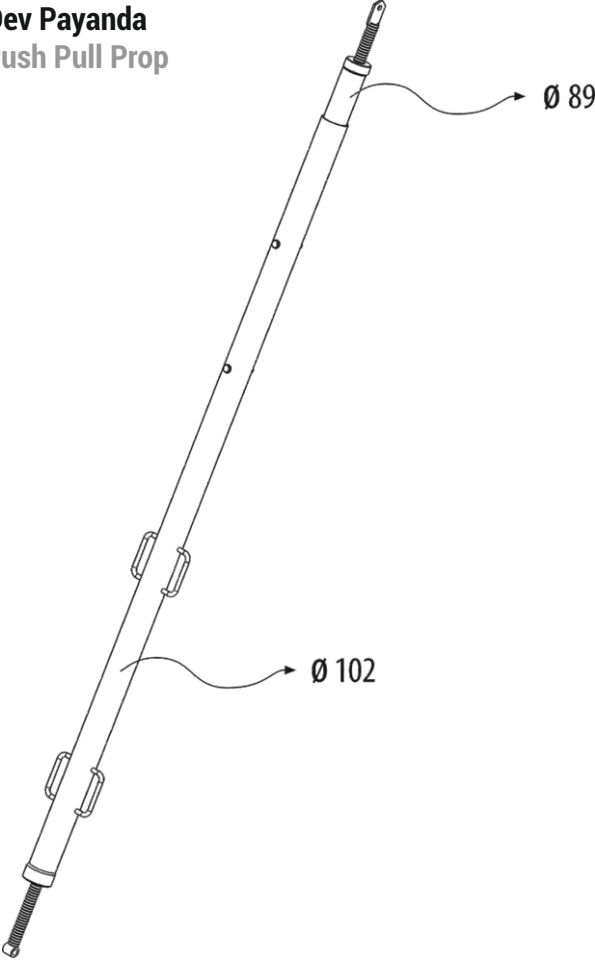
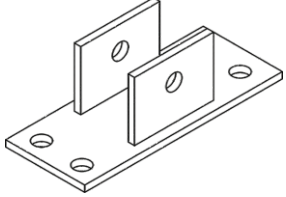
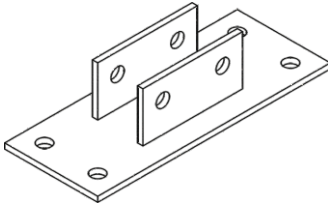
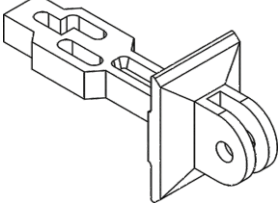
H20 BEAM FORMWORK

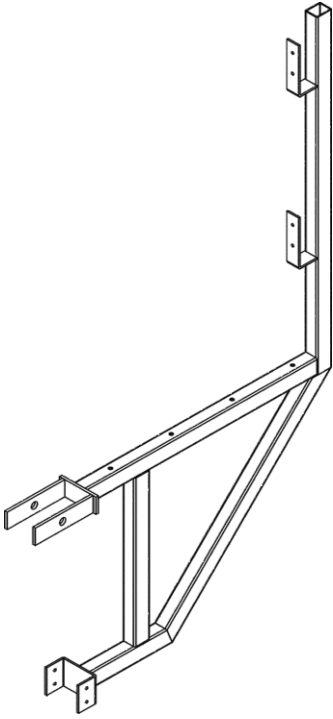
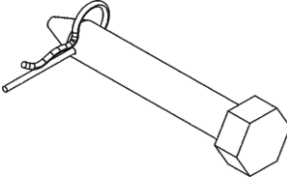
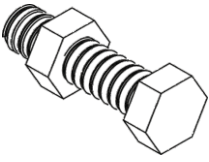
	AĞIRLIK WEIGHT KG	UZUNLUĞU LENGTH	ÜRÜN KODU CODE
Teleskopik Dev Payanda Telescopic Push Pull Prop 	151,50	650/1050	101904
Payanda Tabanı Tekli Telescopic Push Pull Prop 	2,00		102101
Payanda Tabanı Çiftli Base Plate Double 	3,00		102102
Payanda Kafası Push Pull Prop Head 	1,90		102102

AĞIRLIK WEIGHT KG	UZUNLUĞU LENGTH	ÜRÜN KODU CODE		
0,70		102203		Payanda Kaması Push Pull Prop Wedge
10,00		102801		Çalışma Konsolu Scaffold Bracket
0,10 0,15	16*80 20*130	300601 300602		Pim ve Kopilya Pin and Split Pin
0,10 0,15	16*60 16*120	300701 300704		Civata ve Somun Bolt and Nut
0,01 0,01	6*60 6*80	300902 300903		Ahşap Vidası Screw

*“The Future
is Ours”*



FORMWORK and SCAFFOLDING

Your solution partner since 96

HEADQUARTERS - DİLOVASI

Address : Dilovası Mermerciler Sanayi Sitesi 3. Cd. No:40 Köseler Köyü
Dilovası / KOCAELİ / TÜRKİYE

Phone : +90 262 742 06 37
Fax : +90 262 742 08 37
Web : ozleriskele.com
E-mail : info@ozleriskele.com - fabrika@ozleriskele.com

EGE BRANCH

Address : Kavaklıdere Mah. Ankara Cd. No:405/1
Bornova / İZMİR

Phone : +90 232 479 01 37
Responsible Person : Erdi AYHAN
E-mail : erdi.ayhan@ozleriskele.com