



Your solution partner since 96

SLABFORM

SHORING SCAFFOLDING



SLABFORM / MASA TİPİ KALIP İSKELESİ SİSTEMİ

SLABFORM döşeme ve kiriş altında taşıyıcı iskele olarak kullanılır. Masa kalıbı, ağır yük iskelesi ve merdiven kulesi gibi 3 farklı şekilde kullanılabilir. Zemini teraziye almak için TS EN 74-3 sertifikalı alt ayar milleri, döşeme ve kiriş altını teraziye almak için ise 4 yollu veya U başlıklı üst ayar milleri kullanılır. Slabform demonte edilmeden taşıma arabaları ve vinç ile deplase edilebildiği için işçilik maliyetlerinden ve zamandan tasarruf sağlar. Çerçevesel standart olarak 150 cm genişliğinde ve 120 - 150 - 180 - 200 cm yüksekliğinde üretilir. TS EN 12813 sertifikalı Slabform çerçeveler 60*3,0 veya 60*4,0 mm, yatay ve diyagonal bağlantılar ise 34*2,5 mm TSE belgeli mekanik testlere tabi tutulmuş sanayi borularından üretilir. Üretimlerimizde robotik kesme, delme ve kaynak prosesleri uygulanmaktadır. Çerçevesel fırın boya işlemine tabi tutulmadan önce kumlama yapılarak yüzeyindeki kimyasal yağlardan arındırılır. Ayrıca talep halinde ürünlerimiz TS 914 EN ISO 1461 standartlarına göre daldırma galvaniz kaplanabilir.

SLABFORM / SHORING SYSTEM - TABLE TYPE

SLABFORM is used as carrier scaffolding under slab and beam. It can be used in 3 different ways such as table form, heavy load scaffold and stair tower. TS EN 74-3 certified base and head jacks are used to balance the floor and the bottom of the formwork. The SLABFORM can be displaced by transport trolleys and crane without disassembling, thus saving labor costs and time. The frames are manufactured as 150 cm width and 120 - 150 - 180 - 200 cm high as standard. TS EN 12813 certified SLABFORM frames are produced from 60 * 3.0 or 60 * 4.0 mm, and horizontal and diagonal braces are produced from 34 * 2.5 mm TSE certified mechanical tubes. Robotic cutting, drilling and welding processes are applied in our production. The steel products are cleaned with sandblasting before oven painting because of the industrial chemical oil. Upon request, our products can be hot dip galvanized according to TS 914 EN ISO 1461 standards.

SLABFORM

SHORING SCAFFOLDING

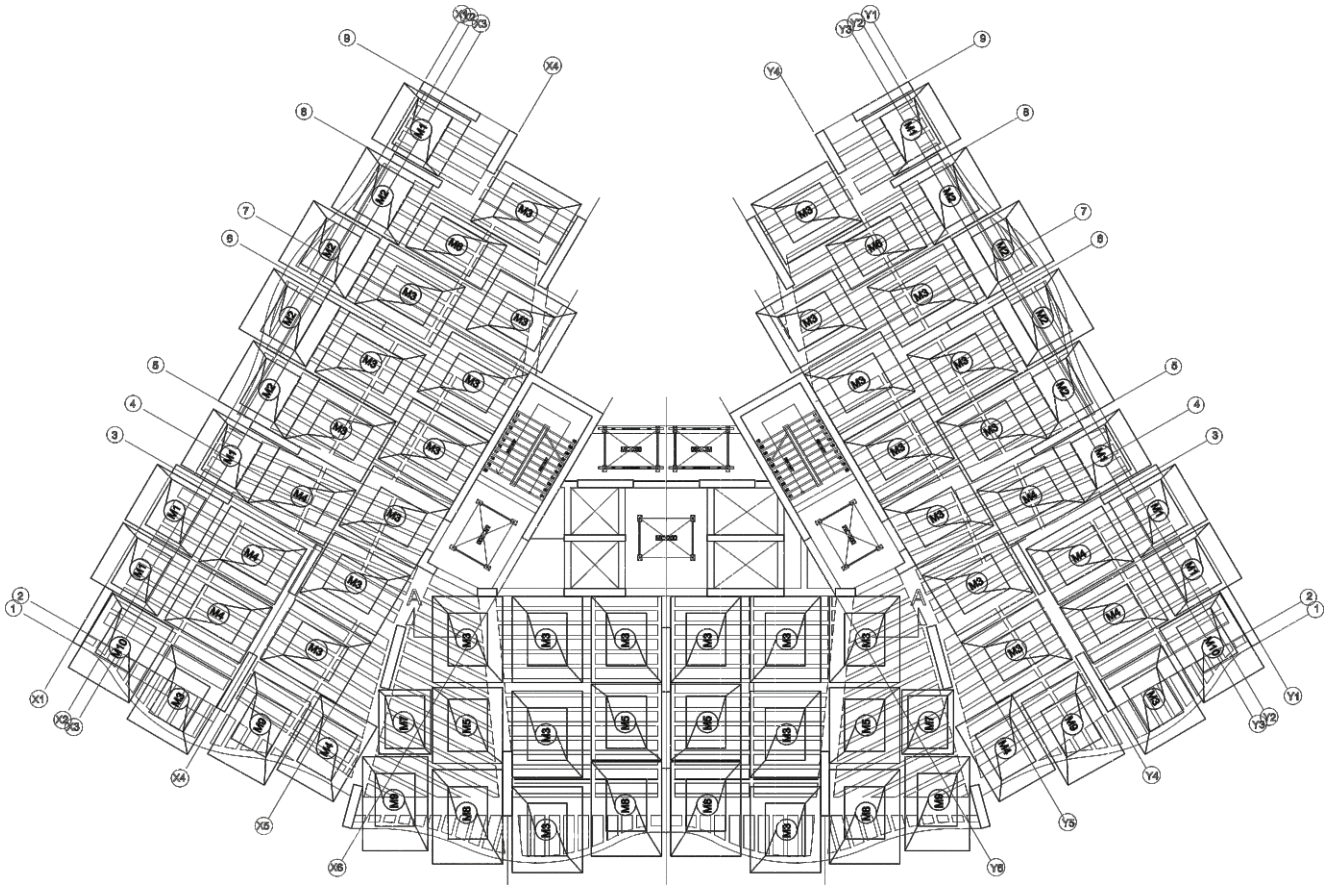

GRUND, 1.2.3.4.5.6.7.8.9.10.11.12.13.14.15.16.17 AND 18. FLOOR FORMWORK CAD PLAN (1/50)



Slabform shoring systems application

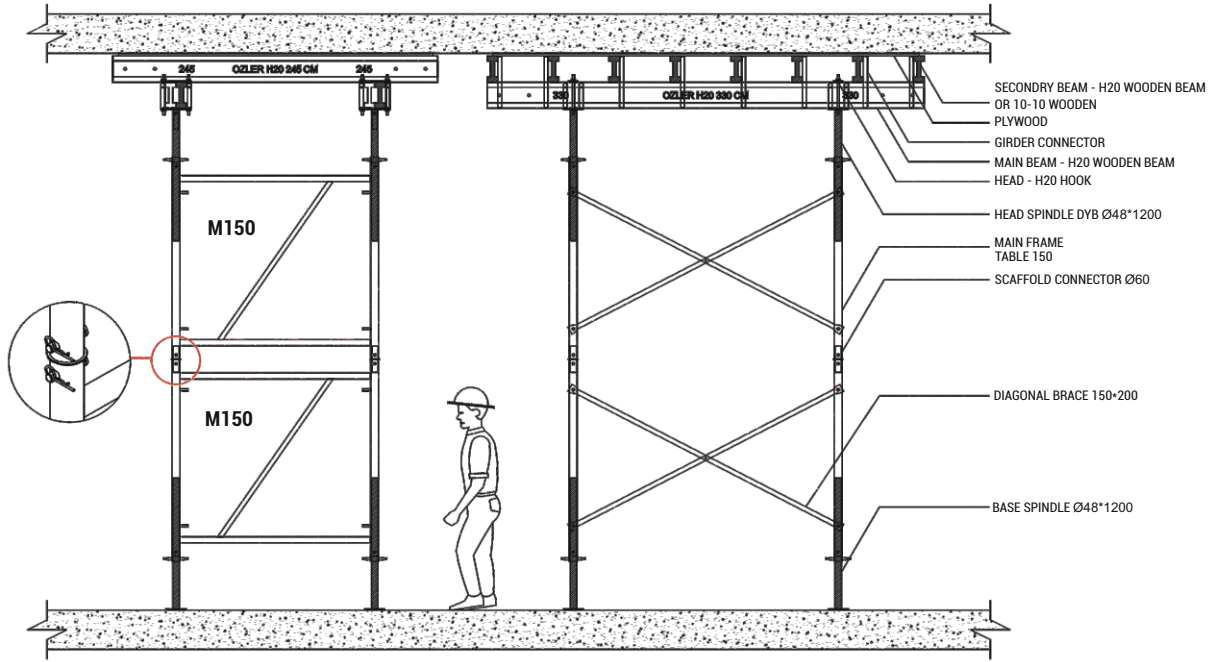
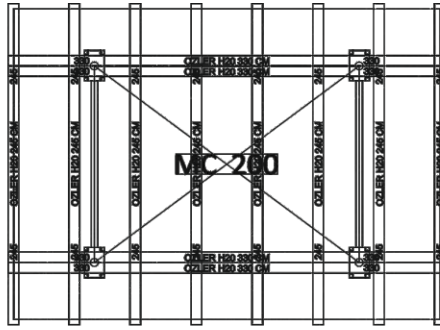

Max. Capacity Of Table Safety bracket is 125kg

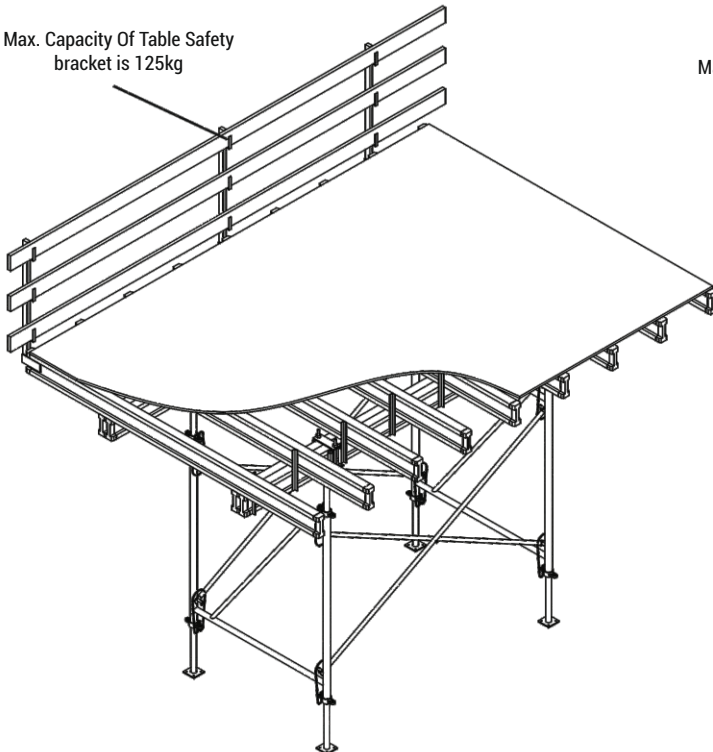

Max. Capacity Of Table lifting component is 750 kg

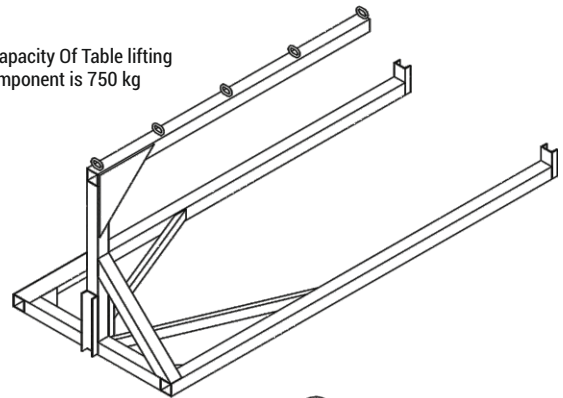

Max. Capacity Of Table carrier is 500kg

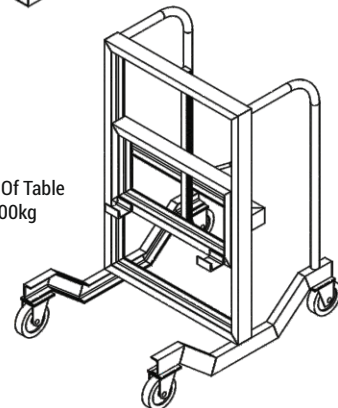

Typical installation of frame

SLABFORM

SHORING SCAFFOLDING

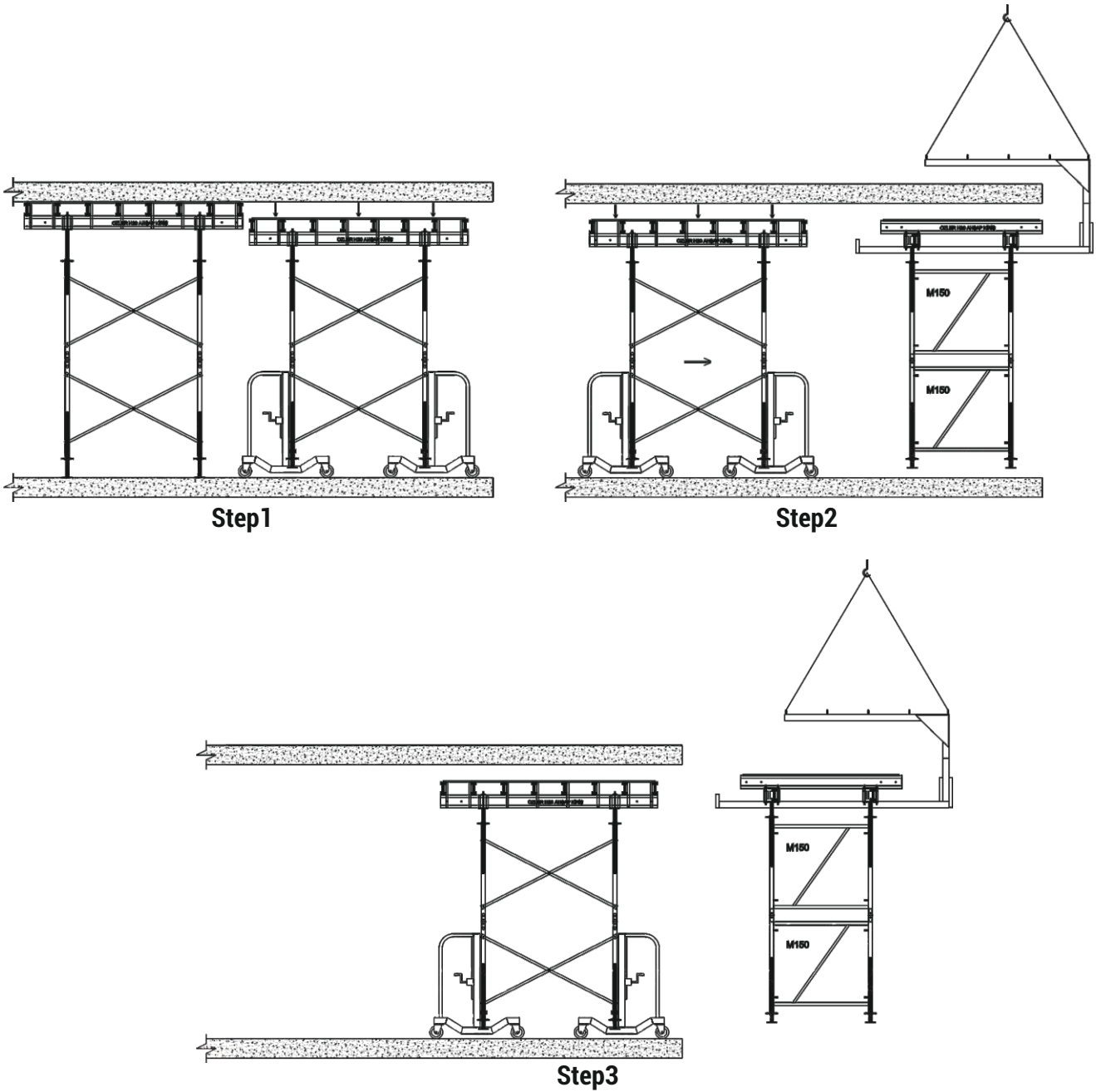

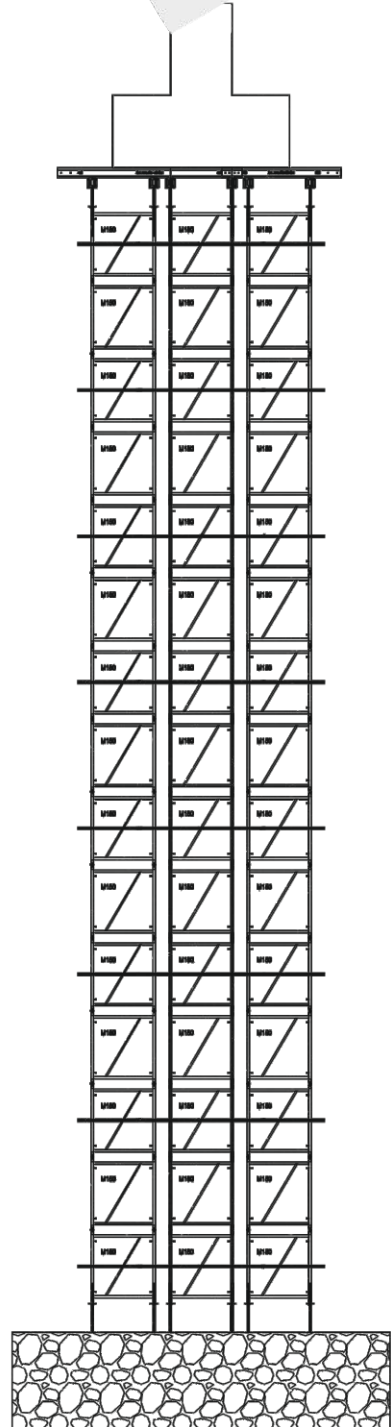
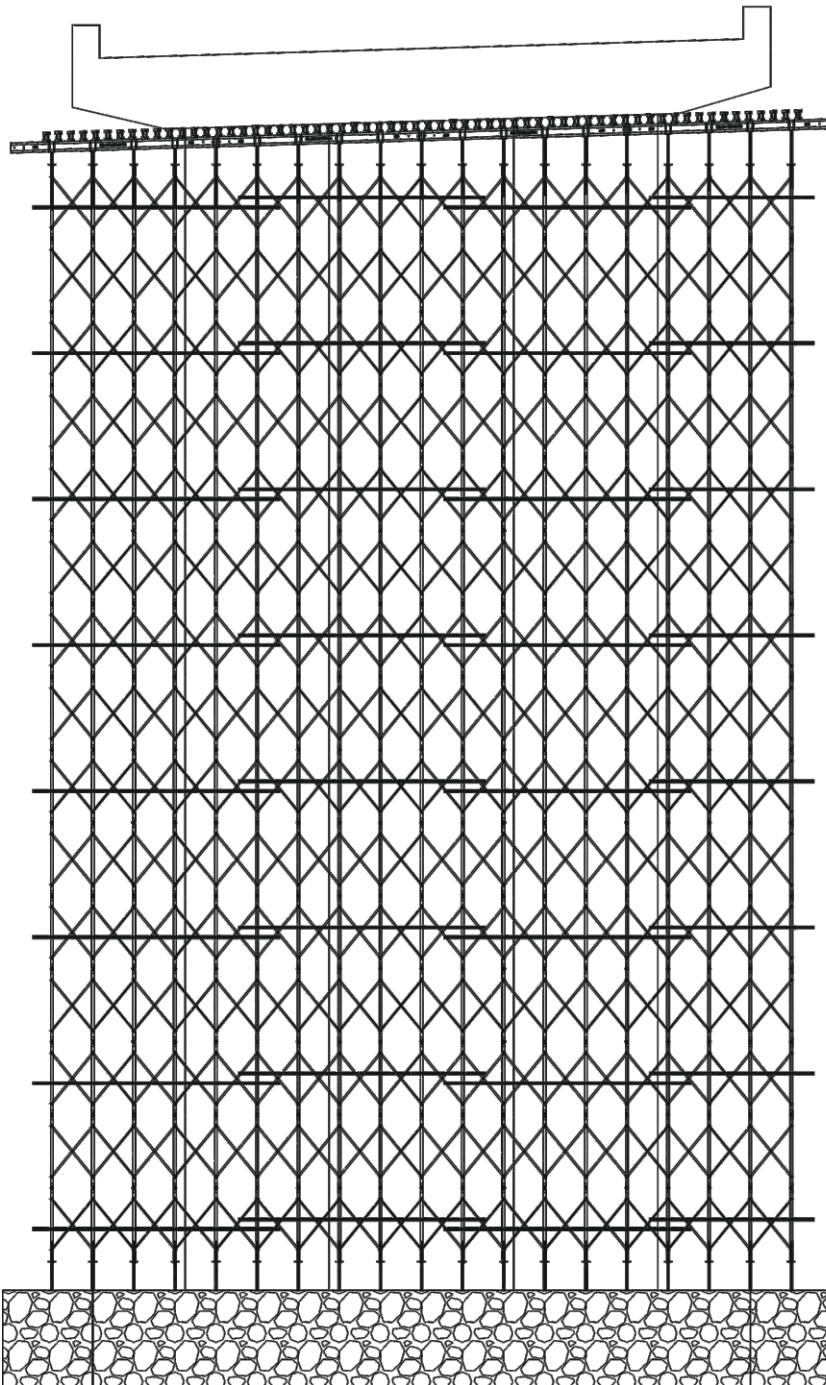
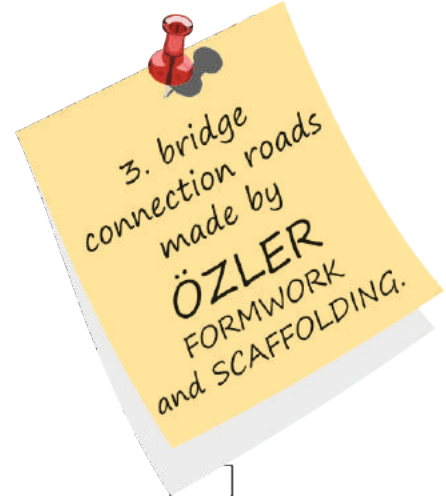
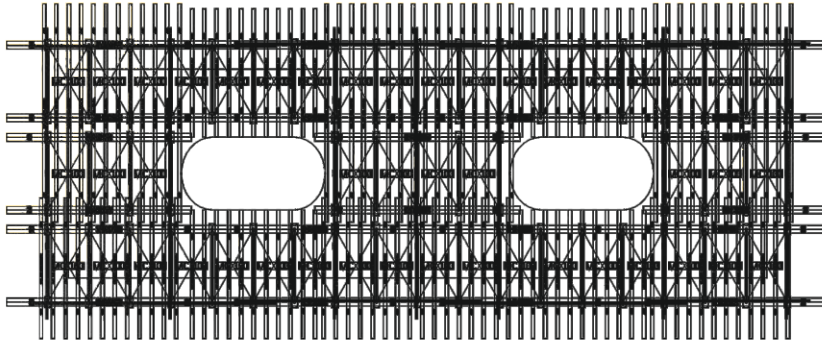

SLABFORM

SHORING SCAFFOLDING

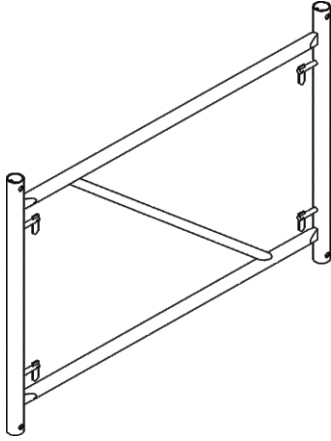
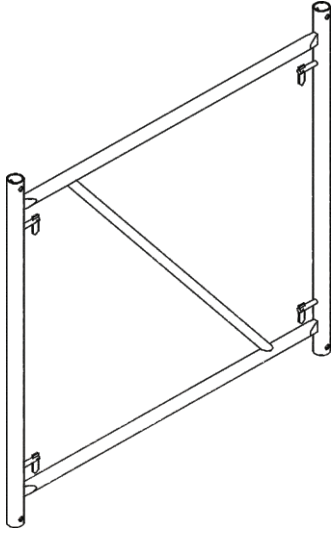
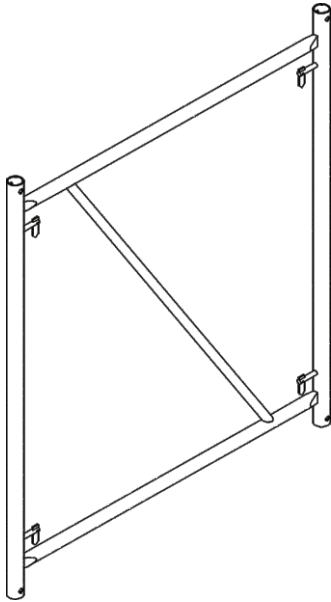

		AĞIRLIK KG WEIGHT KG	UZUNLUĞU LENGHT	ÜRÜN KODU CODE	
Masa İskele 150/110 Main Frame 150/110		Ø60*3,0	19,85	150/110	120101
		Ø60*3,6	21,60	150/110	120102
		Ø60*4,0	22,70	150/110	120103
Masa İskele 150/150 Main Frame 150/150		Ø60*3,0	23,70	150/150	120201
		Ø60*3,6	26,00	150/150	120202
		Ø60*4,0	27,60	150/150	120203
Masa İskele 150/180 Main Frame 150/180		Ø60*3,0	26,60	150/180	120301
		Ø60*3,6	29,45	150/180	120302
		Ø60*4,0	31,30	150/180	120303

SLABFORM

SHORING SCAFFOLDING

AĞIRLIK KG WEIGHT KG	UZUNLUĞU LENGHT	ÜRÜN KODU CODE		
28,40 31,55 33,60	150/200 150/200 150/200	120401 120402 120403	Ø60*3,0 Ø60*3,6 Ø60*4,0	Masa İskele 150/200 Main Frame 150/200
5,60 7,10 8,60	150 200 250	120501 120502 120503		Yatay Bağlantı Horizontal Brace
5,20 6,00 6,70 7,50 8,30 5,85 6,50 7,20 7,95 8,70 6,45 7,05 7,70 8,40 9,10	110/150 110/175 110/200 110/225 150/150 150/175 150/200 150/225 150/250 180-200/150 180-200/175 180-200/200 180-200/225 180-200/250	120603 120604 120605 120606 120607 120703 120704 120705 120706 120707 120803 120804 120805 120806 120807		Çapraz Bağlantı TK. Diagonal Brace

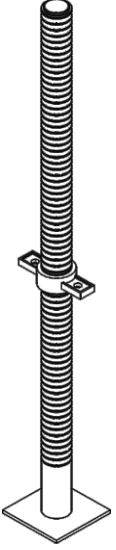
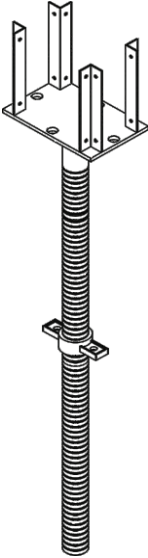
		AĞIRLIK KG WEIGHT KG	UZUNLUĞU LENGHT	ÜRÜN KODU CODE
Ayar Mili Spindle		5,00	Ø48*1000	120901
		6,00	Ø48*1200	120902
		7,50	Ø48*1500	120903
Alt Ayar Mili Base Spindle		6,50	Ø48*1000	121001
		7,50	Ø48*1200	121002
		9,00	Ø48*1500	121003
Ayar Mili DYB Head Spindle DYB		10,50	Ø48*1000	121101
		11,50	Ø48*1200	121102
		13,00	Ø48*1500	121103

SLABFORM

SHORING SCAFFOLDING

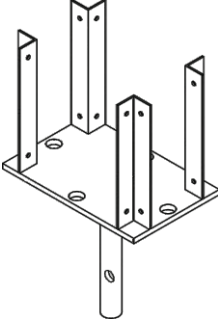
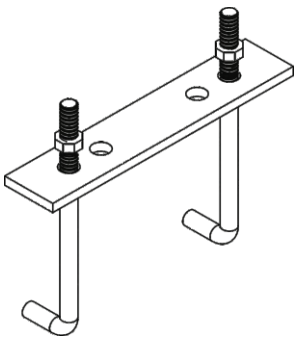
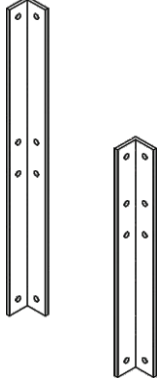
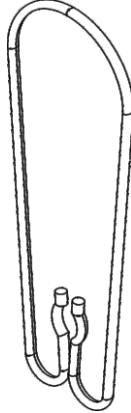
AĞIRLIK KG WEIGHT KG	UZUNLUĐU LENGHT	ÜRÜN KODU CODE	
3,00 4,50	Eco Standard	121201 121202	 <p>Dört Yollu Başlık Head - H20</p>
2,50		121203	 <p>DYB-H20 Bağlama Elemanı Tk Head - H20 Hook</p>
0,45 0,60	30*30 30*30	121301 121302	L=300 L=400  <p>Kiriş Bağlama Köşebent Girder Connector</p>
0,10		121401	 <p>Ayar Mili Kancası Spindle Hook</p>

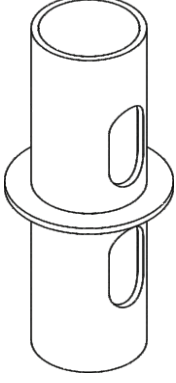
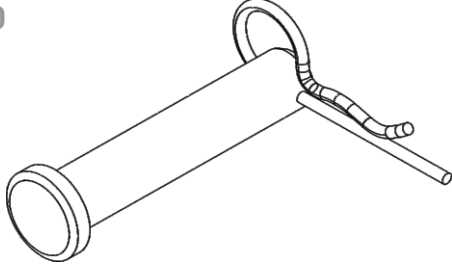
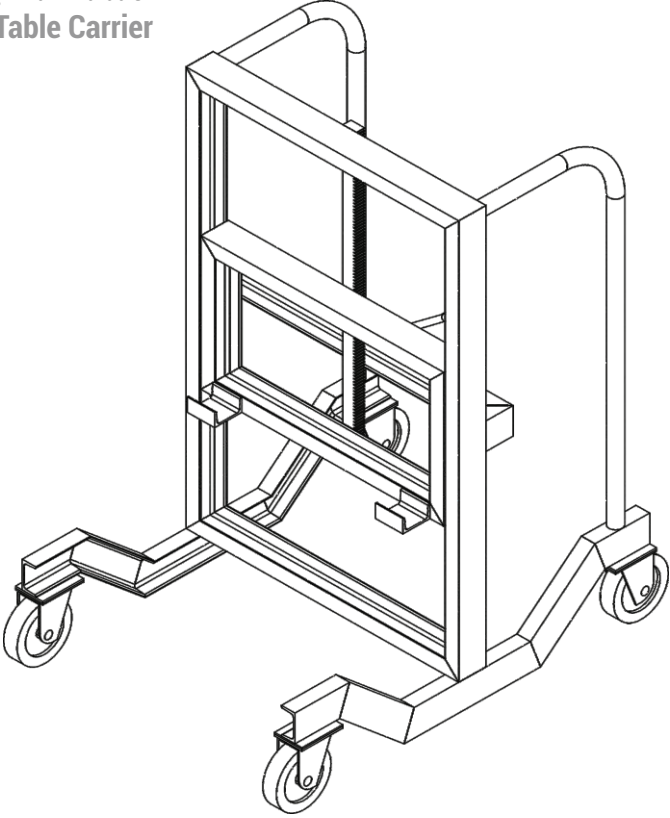
	AĞIRLIK KG WEIGHT KG	UZUNLUĞU LENGHT	ÜRÜN KODU CODE
İskele Ekleme Elemanı Ø60 Scaffold Connector Ø60 	0,50		121501
Pim ve Kopilya 16*80 Pin and Split 16*80 	0,10		300601
Masa Taşıma Arabası Table Carrier 	100,00		121701

SLABFORM

SHORING SCAFFOLDING

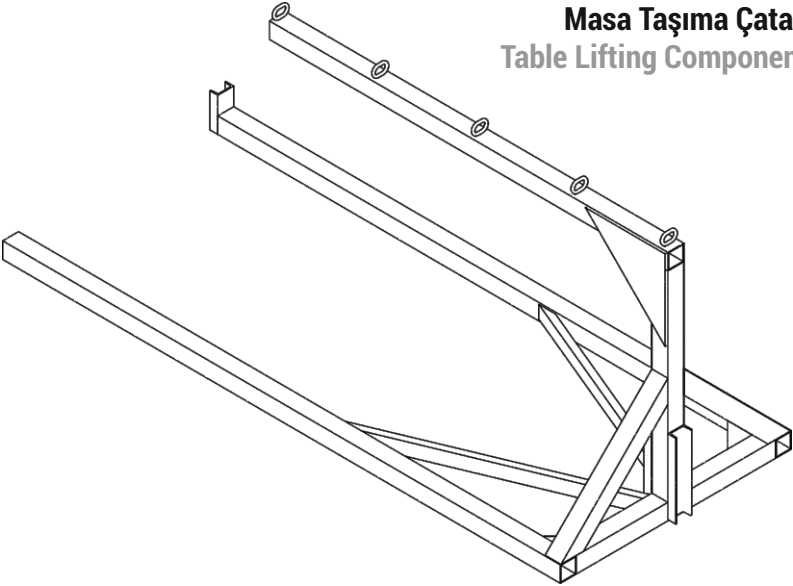
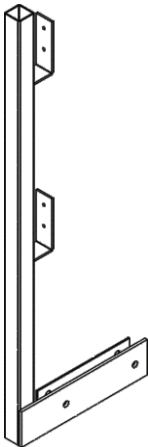
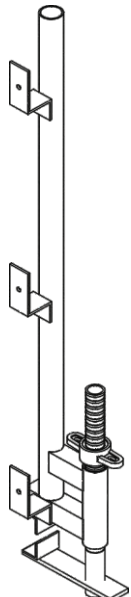
AĞIRLIK KG WEIGHT KG	UZUNLUĐU LENGHT	ÜRÜN KODU CODE	
440,00		121801	 <p>Masa Taşıma Çatalı Table Lifting Component</p>
7,00 8,50	145 170	121901 121902	 <p>Masa Alın Korkuluđu H20 Table Safety Bracket H20</p>
7,20 11,00	170 195	121903 121904	 <p>Masa Alın Korkuluđu 10/10 Table Safety Bracket 10/10</p>

“The Future
is Ours”



FORMWORK and SCAFFOLDING

Your solution partner since 96

HEADQUARTERS - DİLOVASI

Address : Dilovası Mermerciler Sanayi Sitesi 3. Cd. No:40 Köseler Köyü
Dilovası / KOCAELİ / TÜRKİYE

Phone : +90 262 742 06 37
Fax : +90 262 742 08 37
Web : ozleriskele.com
E-mail : info@ozleriskele.com - fabrika@ozleriskele.com

EGE BRANCH

Address : Kavaklıdere Mah. Ankara Cd. No:405/1
Bornova / İZMİR

Phone : +90 232 479 01 37
Responsible Person : Erdi AYHAN
E-mail : erdi.ayhan@ozleriskele.com